

**GUDLAVALLERU ENGINEERING COLLEGE**  
(An Autonomous Institute with Permanent Affiliation to JNTUK, Kakinada)  
Seshadri Rao Knowledge Village, Gudlavalleru – 521 356.

**Department of Computer Science and Engineering**



**HANDOUT**  
**on**  
**FORMAL LANGUAGES AND AUTOMATA THEORY**

## **Vision**

To be a Centre of Excellence in computer science and engineering education and training to meet the challenging needs of the industry and society.

## **Mission**

- To impart quality education through well-designed curriculum in tune with the growing software needs of the industry.
- To serve our students by inculcating in them problem solving, leadership, teamwork skills and the value of commitment to quality, ethical behavior & respect for others.
- To foster industry-academia relationship for mutual benefit and growth.

## **Program Educational Objectives**

- Identify, analyze, formulate and solve Computer Science and Engineering problems both independently and in a team environment by using the appropriate modern tools.
- Manage software projects with significant technical, legal, ethical, social, environmental and economic considerations.
- Demonstrate commitment and progress in lifelong learning, professional development, leadership and Communicate effectively with professional clients and the public.

# **HANDOUT ON FORMAL LANGUAGES AND AUTOMATA**

## **THEORY**

Class & Sem.: II B.Tech – II Semester

Year :2019-20

Branch : CSE

Credits :3

=====

### **1. Brief History and Scope of the Subject**

- Computer science has two major components:
  - 1) The fundamental ideas and models underlying computing,
  - 2) Engineering techniques for the design of computing systems, both hardware and software, especially the application of theory to design.
- This subject is intended as an introduction to the first area, the fundamental ideas underlying computing. Theoretical computer science had its beginnings in a number of diverse fields: biologists studying models for neural networks, electrical engineers developing switching theory as a tool to hardware design, mathematicians working on the foundations of logic, and linguists investigating grammars for natural languages. Out of these studies came models that are central to theoretical computer science.
- The notions of finite automata and regular expressions (Units 1, 2 and 3) were originally developed with neural networks and switching circuits in mind. Recently, they have served as useful tools in the design of lexical analyzers, the part of a compiler that groups characters into tokens-indivisible units such as variable names and keywords. A number of compiler-writing systems automatically transform regular expressions into finite automata for use as lexical analyzers. A number of other uses for regular expressions and finite automata have been found in text editors, pattern matching, various text-processing and file-searching programs, and as mathematical concepts with application to other areas, such as logic.
- The notion of a context-free grammar and the corresponding pushdown automaton (Units 4 and 5) has aided immensely the specification of programming languages and in the design of parsers-another key portion of a compiler. Formal specifications of programming languages have replaced extensive and often incomplete or ambiguous descriptions of languages. Understanding the capabilities of the pushdown automaton has greatly simplified parsing. In early compilers, parser design is a difficult problem, and many of the early parsers were quite inefficient and unnecessarily restrictive. Based on context-free-grammar-based techniques, parser design is no longer a problem, and parsing occupies only a few percent of the time spent in typical compilation.
- In Unit 6, we deal with Turing machines and one of the fundamental problems of computer science; there are algorithms for computing functions. There are functions that are simply not computable; that is, there is no computer program that can ever be written.

## 2. Pre-Requisites:

- Mathematical Foundation of Computer Science

## 3. Course Objectives:

- To introduce the classification of machines by their power to recognize languages and to solve problems in computing.
- To familiarize how to employ deterministic and non-deterministic machines.

## 4. Course Outcomes:

Upon successful completion of the course, the students will be able to

1. compare the automata based on their recognizing power.
2. design finite automata for regular languages.
3. reduce DFA by applying minimization algorithm.
4. write regular expressions for regular languages or for DFA by applying Arden's theorem.
5. generate grammar for CFL's.
6. use algorithm to simplify grammar.
7. design PDA's for context free languages.
8. design Turing Machine for the phrase-structured languages.

## 5. Program Outcomes:

Engineering Graduates will be able to:

1. **Engineering knowledge:** Apply the knowledge of mathematics, science, engineering fundamentals, and an engineering specialization to the solution of complex engineering problems.
2. **Problem analysis:** Identify, formulate, review research literature, and analyze complex engineering problems reaching substantiated conclusions using first principles of mathematics, natural sciences, and engineering sciences.
3. **Design/development of solutions:** Design solutions for complex engineering problems and design system components or processes that meet the specified needs with appropriate consideration for the public health and safety, and the cultural, societal, and environmental considerations.
4. **Conduct investigations of complex problems:** Use research-based knowledge and research methods including design of experiments, analysis and interpretation of data, and synthesis of the information to provide valid conclusions.

5. **Modern tool usage:** Create, select, and apply appropriate techniques, resources, and modern engineering and IT tools including prediction and modeling to complex engineering activities with an understanding of the limitations.
6. **The engineer and society:** Apply reasoning informed by the contextual knowledge to assess societal, health, safety, legal and cultural issues and the consequent responsibilities relevant to the professional engineering practice.
7. **Environment and sustainability:** Understand the impact of the professional engineering solutions in societal and environmental contexts, and demonstrate the knowledge of, and need for sustainable development.
8. **Ethics:** Apply ethical principles and commit to professional ethics and responsibilities and norms of the engineering practice.
9. **Individual and team work:** Function effectively as an individual, and as a member or leader in diverse teams, and in multidisciplinary settings.
10. **Communication:** Communicate effectively on complex engineering activities with the engineering community and with society at large, such as, being able to comprehend and write effective reports and design documentation, make effective presentations, and give and receive clear instructions.
11. **Project management and finance:** Demonstrate knowledge and understanding of the engineering and management principles and apply these to one's own work, as a member and leader in a team, to manage projects and in multidisciplinary environments.
12. **Life-long learning:** Recognize the need for, and have the preparation and ability to engage in independent and life-long learning in the broadest context of technological change.

#### 6. Mapping of Course Outcomes with Program Outcomes:

|            | 1 | 2 | 3 | 4 | 5 | 6 | 7 | 8 | 9 | 10 | 11 | 12 |
|------------|---|---|---|---|---|---|---|---|---|----|----|----|
| <b>CO1</b> | H | H |   |   | H |   |   |   |   |    |    |    |
| <b>CO2</b> |   | H | H |   | H |   |   |   |   |    |    |    |
| <b>CO3</b> | H |   | H |   | H |   |   |   |   |    |    |    |
| <b>CO4</b> | M | H |   |   |   |   |   |   |   |    |    |    |

|                         |   |   |   |  |   |  |  |  |  |  |  |  |
|-------------------------|---|---|---|--|---|--|--|--|--|--|--|--|
| <b>CO5</b>              |   | H | M |  | M |  |  |  |  |  |  |  |
| <b>CO6</b>              | M |   |   |  |   |  |  |  |  |  |  |  |
| <b>CO7</b>              | M | H | H |  | M |  |  |  |  |  |  |  |
| <b>CO8</b>              | M | H | H |  | M |  |  |  |  |  |  |  |
| <b>Assessment Value</b> |   |   |   |  |   |  |  |  |  |  |  |  |

### 7. Prescribed Text Books:

- John E. Hopcroft, Rajeev Motwani and Jeffrey D. Ullman J.D., “Introduction to Automata Theory Languages and Computation”, 3rd edition, Pearson Education.
- Lewis H.R., Papdimitriou, “Elements of Theory of Computation”, 2nd edition, PHI.

### 8. Reference Text Books:

- Daniel I.A. Cohen, John Wiley, “Introduction to languages and the Theory of Computation”.
- Sipser, Thomson, “Introduction to Theory of Computation”, 2nd edition.
- Mishra and Chandrashekar, “Theory of computer science - Automata, Languages, and Computation”, 2nd edition, PHI.
- K.Krithivasan and R.Rama; Introduction to Formal Languages, Automata Theory and Computation; Pearson Education, 2009.

### 9. URLs and Other E-Learning Resources

- Basis for a Mathematical TOC:  
<http://www-formal.stanford.edu/jmc/basis1.pdf>
- Finite Automata:  
[http://www.cs.odu.edu/~toida/nerzic/390teched/regular/fa/intr\\_2\\_fa.html](http://www.cs.odu.edu/~toida/nerzic/390teched/regular/fa/intr_2_fa.html)
- PDA: <https://brilliant.org/wiki/pushdown-automata/>
- Turing Machine: <http://plato.stanford.edu/entries/turing-machine>

### 10. Digital Learning Materials:

- <http://nptel.ac.in/courses/106104028/>
- <http://nptel.ac.in/courses/106104148/>
- <http://nptel.ac.in/courses/106106049/>

**11. Lecture Schedule / Lesson Plan (4)**

| Topic   | No. of Periods |          |
|---|----------------|----------|
|   | Theory         | Tutorial |
| <b>UNIT -1: Fundamentals</b>  |                |          |
| Strings, Alphabet, Language, Operations on strings  | 1              | 1        |
| Operations on languages, Finite State System  | 1              |          |
| Finite Automaton Model  | 1              |          |
| Acceptance of strings and languages   | 1              | 2        |
| Deterministic finite automaton  | 2              |          |
| Non deterministic finite automaton  | 2              |          |
| Transition diagrams, language recognizers and applications of Finite Automata                 | 2              |          |
| <b>Total</b>  | <b>10+3(T)</b> |          |
| <b>UNIT - 2: Finite Automata</b>  |                |          |
| NFA with $\epsilon$ transitions – significance, acceptance of a language by a $\epsilon$ -NFA | 1              | 1        |
| Equivalence between NFA with and without $\epsilon$ transitions                               | 2              |          |
| Minimization of FSM   | 2              |          |
| NFA to DFA conversion   | 1              |          |
| equivalence between two FSM's   | 1              |          |
| Finite automata with outputs - Moore machine, Mealy machines                                  | 1              | 1        |
| Moore to Mealy Conversion-examples  | 1              |          |
| Mealy to Moore conversion-examples  | 1              |          |
| <b>Total</b>  | <b>10+2(T)</b> |          |
| <b>UNIT - 3: Regular Languages</b>  |                |          |
| Regular Sets, Identity Rules  | 1              | 1        |
| Regular expressions   | 2              |          |
| Construction of finite Automata for a given regular expressions                               | 1              | 1        |
| Construction of regular expression for a given finite Automata                                | 1              |          |
| Pumping lemma of regular sets   | 1              |          |

|  |   |                |
|--|---|----------------|
| Closure properties of regular sets, applications of regular languages.                       | 1 |                |
| <b>Total</b>   |   | <b>7+2(T)</b>  |
| <b>UNIT – 4: Grammar Formalism</b>   |   |                |
| Chomsky hierarchy of languages   | 1 | 1              |
| Regular grammars - right linear and left linear grammars-examples                            | 1 |                |
| Equivalence between regular linear grammar and FA  | 1 |                |
| Equivalence between FA and regular grammar   | 1 |                |
| Context free grammar-examples  | 2 |                |
| Derivation- Rightmost and leftmost derivation of strings, sentential forms, Derivation trees | 2 | 1              |
| <b>Total</b>   |   | <b>8+2(T)</b>  |
| <b>UNIT – 5: Context Free Grammars</b>   |   |                |
| Ambiguity in context free grammars   | 1 | 1              |
| Minimization of Context Free Grammars  | 1 |                |
| Chomsky normal form  | 1 |                |
| Greibach normal form   | 2 |                |
| Pumping Lemma for Context Free Languages   | 1 |                |
| Enumeration of Properties of CFL (proofs not required), applications of CFLs                 | 1 |                |
| Push down automata, model of PDA   | 1 | 1              |
| Design of PDA  | 2 |                |
| Applications of PDA  | 1 |                |
| <b>Total</b>   |   | <b>11+2(T)</b> |
| <b>UNIT – 6: Turing Machine</b>  |   |                |
| Turing Machine, model  | 1 | 1              |
| Design of TM   | 2 |                |
| Types of Turing Machines   | 1 | 1              |
| Computable functions   | 1 |                |
| Recursively enumerable languages, Recursive languages  | 1 |                |
| Decidability of problems   | 1 |                |
| Undecidability of posts correspondence problem   | 1 |                |



| <b>Total</b>                    | <b>8+2(T)</b> |              |
|---------------------------------|---------------|--------------|
| <b>Total Number of Periods:</b> | <b>54</b>     | <b>13(T)</b> |

**13.Seminar Topics: NIL**

# FORMAL LANGUAGES AND AUTOMATA THEORY

## UNIT-I

### **Objective:**

To familiarize how to employ deterministic and non-deterministic finite automata.

### **Syllabus:**

Strings, alphabet, language, operations, finite state machine, finite automaton model, acceptance of strings and languages, deterministic finite automaton and non deterministic finite automaton, transition diagrams and language recognizers.

### **Learning Outcomes:**

Students will be able to:

- Understand the basic definitions like alphabet, string, language and their operations.
- Understand the model of FA.
- Design DFA and NFA for the given regular language.
- Test the designed DFA and NFA for the set of strings that belongs to L and for the set of strings that doesn't belongs to L.

## 1.Learning Material

### 1.1 Alphabet:

An alphabet is a finite, nonempty set of symbols. It is denoted by  $\Sigma$ .

#### **Example:**

$\Sigma = \{0, 1\}$  is binary alphabet consisting of the symbols 0 and 1.

$\Sigma = \{a, b, c \dots z\}$  is lowercase English alphabet.

### 1.1.1 Powers of an Alphabet

If  $\Sigma$  is an alphabet, we can express the set of all strings of a certain length from that alphabet by using the exponential notation. It is denoted by  $\Sigma^k$  - the set of strings of length k.

#### **Example:**

$\Sigma^0 = \{\epsilon\}$ , regardless of what alphabet  $\Sigma$  is.  $\epsilon$  is the only string of length 0.

If  $\Sigma = \{0, 1\}$  then,

$\Sigma^1 = \{0, 1\}$

$\Sigma^2 = \{00, 01, 10, 11\}$

$\Sigma^3 = \{000, 001, 010, 011, 100, 101, 110, 111\}$

The set of all strings over an alphabet  $\Sigma$  is denoted by  $\Sigma^*$ .  $\Sigma^* = \Sigma^0 \cup \Sigma^1 \cup \Sigma^2 \cup$

$\dots$

For example,  $\{0, 1\}^* = \{\epsilon, 0, 1, 00, 01, 10, 11, 000, \dots\}$

The symbol  $*$  is called **Kleene star** and is named after the mathematician and logician Stephen Cole Kleene.

The symbol  $+$  is called **Positive closure** i.e.  $\Sigma^+ = \Sigma^1 \cup \Sigma^2 \cup \dots$

$$\Sigma^* = \Sigma^+ \cup \{ \epsilon \}$$

### 1.2 String:

A string (or word) is a finite sequence of symbols chosen from some alphabet.

The letters u, v, w, x, y and z are used to denote string.

#### **Example:**

If  $\Sigma = \{a, b, c\}$  then abcb is a string formed from that alphabet.

- The **length** of a string w, denoted  $|w|$ , is the number of symbols composing the string.

#### **Example:**

The string abcb has length 4.

- The **empty string** denoted by  $\epsilon$ , is the string consisting of zero symbols.  
Thus  $|\epsilon| = 0$ .

### 1.2.1 Operations on strings:

- **Concatenation of strings**

The concatenation of two strings is the string formed by writing the first, followed by the second, with no intervening space. Concatenation of strings is denoted by  $\circ$ .

That is, if w and x are strings, then wx is the concatenation of these two strings.

#### **Example:**

The concatenation of dog and house is doghouse.

Let  $x=0100101$  and  $y=1111$  then  $x \circ y=0100101111$

- **String Reversal**

Reversing a string means writing the string backwards. It is denoted by  $w^R$

#### **Example:**

Reverse of the string abcd is dcba.

**If  $w = w^R$ , then that string is called palindrome.**

- **Substring**

A substring is a part of a string.

#### **Example:**

If abcd is string then possible substrings are  $\epsilon, a, b, c, d, ab, bc, cd, abc, bcd$  are proper substrings for the given string

A **prefix** of a string is any number of leading symbols of that string.

A **suffix** of a string is any number of trailing symbols.

**Example:**

String abc has prefixes  $\epsilon$ , a, ab, and abc; its suffixes are  $\epsilon$ , c, bc, and abc.

A prefix or suffix of a string, other than the string itself, is called a **proper prefix or suffix**.

### 1.3 Language:

A (formal) language is a set of strings of symbols from some one alphabet. It is denoted by L. We denote this language by  $\Sigma^*$ .

- The empty set,  $\emptyset$ , and the set consisting of the empty string  $\{\epsilon\}$  are languages.

**Example:**

If  $\Sigma = \{a\}$ , then  $\Sigma^* = \{\epsilon, a, aa, aaa, \dots\}$ .

If  $\Sigma = \{0, 1\}$ , then  $\Sigma^* = \{\epsilon, 0, 1, 00, 01, 10, 11, 000, \dots\}$ .

### 1.4 Operations on languages:

- **Union**

If L1 and L2 are two languages over an alphabet  $\Sigma$ . Then the union of L1 and L2 is denoted by  $L1 \cup L2$ .

**Example:**

$L1 = \{0, 01, 011\}$  and  $L2 = \{001\}$ , then  $L1 \cup L2 = \{0, 01, 011, 001\}$

- **Intersection**

If L1 and L2 are two languages over an alphabet  $\Sigma$ . Then the intersection of L1 and L2 is denoted by  $L1 \cap L2$ .

**Example:**

$L1 = \{0, 01, 011\}$  and  $L2 = \{01\}$ , then  $L1 \cap L2 = \{01\}$

- **Complementation**

**L is a language** over an alphabet  $\Sigma$ , then the complement of L denoted by  $L^-$ , is the language consisting of those strings that are not in L over the alphabet.

**Example:**

If  $\Sigma = \{a, b\}$  and  $L = \{a, b, aa\}$  then  $L^- = \Sigma^* - L = \{\epsilon, a, b, aa, bb, ab, \dots\}$   
 $\{a, b, aa\} = \{\epsilon, bb, ab, ba, \dots\}$

- **Concatenation**

Concatenation of two languages L1 and L2 is the language  $L1 \circ L2$ , each element of which is a string formed by combining one string of L1 with another string of L2.

**Example:**

$L1 = \{bc, bcc, cc\}$  and  $L2 = \{cc, ccc\}$ , then  $L1 \circ L2 = \{bcc, bcccc, bccccc, cccc, cccc$

c}

- **Reversal**

If  $L$  is language, then  $L^R$  is obtained by reversing the corresponding string in  $L$ . This operation is similar to the reversal of a string.

$$L^R = \{w^R \mid w \in L\}$$

**Example:**

If  $L = \{0, 011, 0111\}$ , then  $L^R = \{0, 110, 1110\}$

• **Kleene Closure**

The Kleene closure (or just closure) of  $L$ , denoted  $L^*$ , is the set

$$L^* = \bigcup_{i=0}^{\infty} L^i$$

and the positive closure of  $L$ , denoted  $L^+$ , is the set

$$L^+ = \bigcup_{i=1}^{\infty} L^i$$

That is,  $L^*$  denotes words constructed by concatenating any number of words from  $L$ .

$L^+$  is the same, but the case of zero words, whose "concatenation" is defined to be  $\epsilon$ , is excluded. Note that  $L^+$  contains  $\epsilon$  if and only if  $L$  does.

**Example:**

Let  $L_1 = \{10, 1\}$

Then  $L^* = L_0 \cup L_1 \cup L_2 \dots = \{\epsilon, 1, 10, 11, 111, 1111, \dots\}$

$L^+ = L_1 \cup L_2 \cup L_3 \dots = \{1, 10, 11, 111, 1111, \dots\}$

**1.5 Finite Automaton:**

- A finite automaton (FA) consists of a finite set of states and a set of transitions from state to state that occur on input symbols chosen from an alphabet  $\Sigma$ .
- For each input symbol there is exactly one transition out of each state (possibly back to the state itself).
- One state, usually denoted  $q_0$  is the initial state, in which the automaton starts. Some states are designated as final or accepting states.

Formally, a finite automaton is denoted by a 5-tuple  $(Q, \Sigma, \delta, q_0, F)$ , where

- $Q$  is a finite set of states.
- $\Sigma$  is a finite input alphabet.
- $\delta$  is the transition function mapping  $Q \times \Sigma$  to  $Q$  i.e.,  $\delta(q, a)$  is a state for each state  $q$  and input symbol  $a$ .
- $q_0 \in Q$  is the initial state.
- $F \subseteq Q$  is the set of final states. It is assumed here that there may be

- more than one final state.

### **Transition Diagram**

- A transition diagram is a directed graph associated with an FA in which the vertices of the graph correspond to the states of the FA.
- If there is a transition from state  $q$  to state  $p$  on input  $a$ , then there is an arc labelled  $a$  from state  $q$  to state  $p$  in the transition diagram.

State is denoted by 

Transition is denoted by 

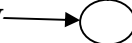
Initial state is denoted by 

Final state is denoted by 

### **Transition Table**

A tabular representation in which rows correspond to states, columns correspond to inputs and entries correspond to next states.

### **1.6 Finite Automata Model:**

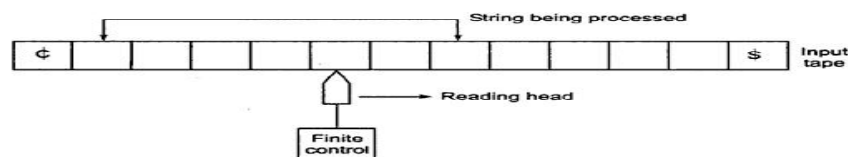

**Block diagram of a finite automaton**

The various components are explained as follows:

(i) **Input tape:**

- The input tape is divided into squares, each square containing a single symbol from the input alphabet  $\Sigma$ .
- The end squares of the tape contain the endmarker  $\text{¢}$  at the left end and the endmarker  $\text{\$}$  at the right end.
- The absence of endmarkers indicates that the tape is of infinite length. The left-to-right sequence of symbols between the two endmarkers is the input string to be processed.

(ii) **Reading head:**

- The head examines only one square at a time and can move one square either to the left or to the right.
- For further analysis, we restrict the movement of the R-head only to the right side.

(iii) **Finite control:** The input to the finite control will usually be the symbol under the R-head, say a, and the present state of the machine, say q, to give the following outputs:

- (a) A motion of R-head along the tape to the next square (in some a null move, i.e. the R-head remaining to the same square is permitted)
- (b) The next state of the finite state machine given by  $\delta(q, a)$ .

**1.7 Acceptance of String by a Finite Automaton:**

The FA accepts a string x if the sequence of transitions corresponding to the symbols of x leads from the start state to an accepting state and the entire string has to be consumed, i.e., a string x is accepted by a finite automaton  $M = (Q, \Sigma, \delta, q_0, F)$

if  $\delta(q_0, x) = q$  for some  $q \in F$ .

This is basically the acceptability of a string by the final state.

**Note: A final state is also called an accepting state.**

Transition function  $\delta$  and for any two input strings x and y,

$\delta(q, xy) = \delta(\delta(q, x), y)$

**Example:**

Consider the finite state machine whose transition function  $\delta$  is given in the form of a transition table. Here  $Q = \{q_0, q_1, q_2, q_3\}, \Sigma = \{0, 1\}, F = \{q_0\}$ . Give the entire sequence of states for the input string 110101.

**Transition Table**

| State            | Input          |                |
|------------------|----------------|----------------|
|                  | 0              | 1              |
| → q <sub>0</sub> | q <sub>2</sub> | q <sub>1</sub> |
| q <sub>1</sub>   | q <sub>3</sub> | q <sub>0</sub> |
| q <sub>2</sub>   | q <sub>0</sub> | q <sub>3</sub> |
| q <sub>3</sub>   | q <sub>1</sub> | q <sub>2</sub> |

$$\begin{aligned}
 \delta(q_0, 110101) &= \delta(q_1, 10101) \\
 &= \delta(q_0, 0101) \\
 &= \delta(q_2, 101) \\
 &= \delta(q_3, 01)
 \end{aligned}$$

$$= \delta(q_2, 1)$$

$$= q_0$$

$q_0$  is final state, therefore given string is accepted by finite automata.

### 1.8 Deterministic finite automaton:

Formally, a deterministic finite automaton can be represented by a 5-tuple

$$M = (Q, \Sigma, \delta, q_0, F).$$

where

- $Q$  is a finite set of states.
- $\Sigma$  is a finite input alphabet.
- $\delta$  is the transition function mapping  $Q \times \Sigma$  to  $Q$  i.e.,  $\delta(q, a)$  is a state for each state  $q$  and input symbol  $a$ .
- $q_0 \in Q$  is the initial state.
- $F \subseteq Q$  is the set of final states. It is assumed here that there may be more than one final state.

#### **Steps to design a DFA**

1. Understand the language for which the DFA has to be designed and write the language for the set of strings starting with minimum string that are accepted by FA.
2. Draw transition diagram for the minimum length string.
3. Obtain the possible transitions to be made for each state on each input symbol.
4. Draw the transition table.
5. Test DFA with few strings that are accepted and few strings that are rejected by the given language.
6. Represent DFA with tuples.

#### **Examples**

##### **1. Design DFA that accepts all strings which starts with '1' over the alphabet {0,1}**

**Step 1:** Understand the language for which the DFA has to be designed and write the language for the set of strings starting with minimum string that is accepted by FA.

$$L = \{1, 10, 11, 100, 110, 101, 111, \dots\}$$

**Step 2:** Draw transition diagram for the minimum length string.

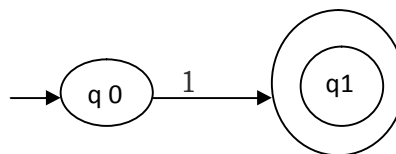

**Step 3:** Obtain the possible transitions to be made for each state on each input symbol.



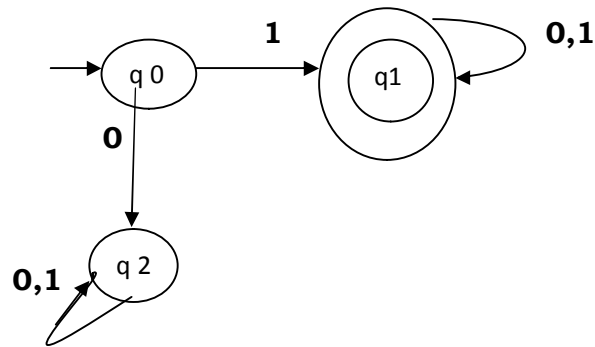

**Step 4:** Draw the transition table.

| State          | Input          |                |
|----------------|----------------|----------------|
|                | 0              | 1              |
| q <sub>0</sub> | q <sub>2</sub> | q <sub>1</sub> |
| q <sub>1</sub> | q <sub>1</sub> | q <sub>1</sub> |
| q <sub>2</sub> | q <sub>2</sub> | q <sub>2</sub> |

**Step 5:** Test DFA with few strings that are accepted and few strings that are rejected by the given language.

**Case i)** Let  $w=1001 \in L$

$$\begin{aligned} \delta(q_0, 1001) &= \delta(q_1, 010) \\ &= \delta(q_1, 10) = \delta(q_1, 0) = q_1 \end{aligned}$$

$q_1$  is final state and the entire string has been consumed i.e., given string is accepted by DFA.

**Case ii)** Let  $w=0001 \notin L$

$$\begin{aligned} \delta(q_0, 0001) &= \delta(q_2, 001) \\ &= \delta(q_2, 10) \\ &= \delta(q_2, 0) \\ &= q_2 \end{aligned}$$

$q_2$  is not final state and the entire string has been consumed i.e., given string is rejected by DFA.

**Step 6:** Represent DFA with tuples.

DFA,  $M = (Q, \Sigma, \delta, q_0, F)$

where  $Q = \{q_0, q_1, q_2\}$

$\Sigma = \{0, 1\}$

$$\delta: \delta(q_0, 0) = q_2$$

$$\delta(q_0, 1) = q_1$$

$$\delta(q_1, 0) = q_1$$

$$\delta(q_1, 1) = q_1$$

$$\delta(q_2, 0) = q_2$$

$$\delta(q_2, 1) = q_2$$

$q_0$  – initial state

F – final state =  $\{q_1\}$

## 2. Design DFA that accepts all strings which contains '00' as substring over the alphabet {0,1}

**Step 1:** Understand the language for which the DFA has to be designed and write the language for the set of strings starting with minimum string that is accepted by FA.

$L = \{00, 100, 000, 001, 1100, 1000, 0100, 1001, 0001, 11000, 11100, \dots\}$

**Step 2:** Draw transition diagram for the minimum length string.

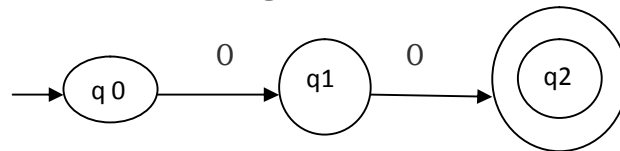

**Step 3 :** Obtain the possible transitions to be made for each state on each input symbol.

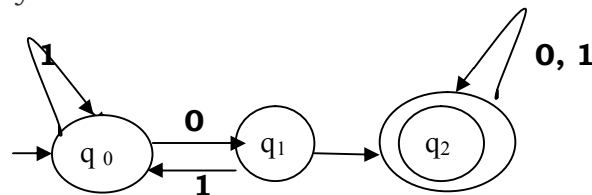

**Step 4:** Draw the transition table.

| State | Input |   |
|-------|-------|---|
|       | 0     | 1 |
|       |       |   |

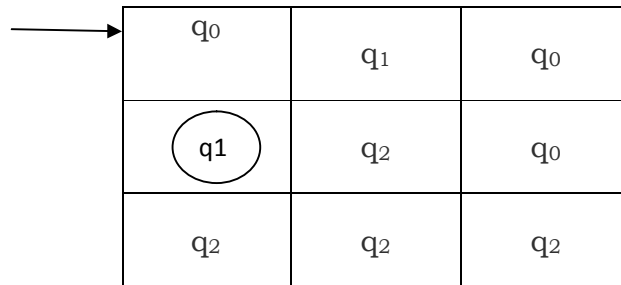

**Step 5:** Test DFA with few strings that are accepted and few strings that are rejected by the given language.

**Case i)** Let  $w = 1001 \in L$

$$\begin{aligned} \delta(q_0, 1001) &= \delta(q_0, 001) \\ &= \delta(q_1, 01) \\ &= \delta(q_2, 1) \\ &= q_2 \end{aligned}$$

It is final state and the entire string has been consumed i.e., given string is accepted by DFA.

**Case ii)** Let  $w = 1011 \notin L$

$$\begin{aligned} \delta(q_0, 1011) &= \delta(q_0, 011) \\ &= \delta(q_1, 11) \\ &= \delta(q_0, 1) \\ &= q_0 \end{aligned}$$

It is not final state and the entire string has been consumed i.e., given string is rejected by DFA.

**Step 6:** Represent DFA with tuples.

DFA,  $M = (\mathbf{Q}, \Sigma, \delta, \mathbf{q}_0, \mathbf{F})$

where  $Q = \{q_0, q_1, q_2\}$

$$\Sigma = \{0, 1\}$$

$$\delta: \delta(q_0, 0) = q_1$$

$$\delta(q_0, 1) = q_0$$

$$\delta(q_1, 0) = q_2$$

$$\delta(q_1, 1) = q_0$$

$$\delta(q_2, 0) = q_2$$

$$\delta(q_2, 1) = q_2$$

$q_0$  – initial state

F – final state =  $\{q_2\}$

### **1.9 Nondeterministic finite automaton (NFA/NFA):**

A nondeterministic finite automaton is a 5-tuple  $(Q, \Sigma, \delta, q_0, F)$ , where

- $Q$  is a finite nonempty set of states;
- $\Sigma$  is a finite nonempty set of inputs;
- $\delta$  is the transition function mapping from  $Q \times \Sigma$  into  $2^Q$  which is the power set of  $Q$ , the set of all subsets of  $Q$ ;
- $q_0 \in Q$  is the initial state; and
- $F \subseteq Q$  is the set of final states

#### ***Steps to design a NFA***

1. Understand the language for which the NFA has to be designed and write the language for the set of strings starting with minimum string that is accepted by FA.
2. Draw transition diagram for the minimum length string.
3. Obtain the possible transitions to be made for each state on each input symbol.
4. Draw the transition table.
5. Test NFA with few strings that are accepted and few strings that are rejected by the given language.
6. Represent NFA with tuples.

#### ***Examples:***

1. **Design NFA that accepts all strings which contains '00' as substring over the alphabet  $\{0,1\}$**

**Step 1:** Understand the language for which the NFA has to be designed and write the language for the set of strings starting with minimum string that is accepted by FA

$L = \{00, 100, 000, 001, 0100, 1100, 1000, 1001, 0001, 11000, 11100, \dots\}$

**Step 2:** Draw transition diagram for the minimum string.

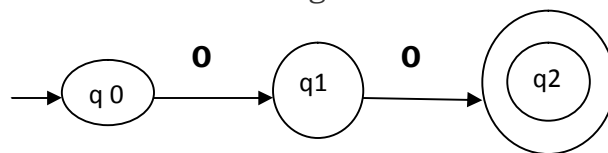

**Step 3:** Obtain the possible transitions to be made for each state on each input symbol.

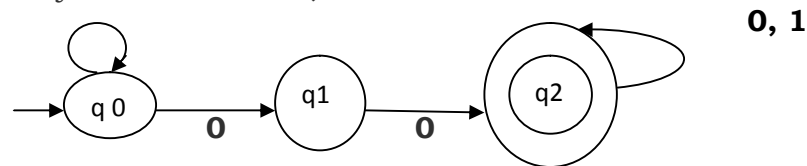

**Step 4:** Draw the transition table.

| State          | Input                              |                |
|----------------|------------------------------------|----------------|
|                | 0                                  | 1              |
| q <sub>0</sub> | {q <sub>0</sub> , q <sub>1</sub> } | q <sub>0</sub> |
| q <sub>1</sub> | q <sub>2</sub>                     | -              |
| q <sub>2</sub> | q <sub>2</sub>                     | q <sub>2</sub> |

**Step 5:** Test NFA with few strings that are accepted and few strings that are rejected by the given language.

**Case i)** Let  $w=0100 \in L$

$$\begin{aligned} \delta(q_0, 0100) &= \delta(\{q_0, q_1\}, 100) \\ &= \delta(q_0, 00) \\ &= \delta(\{q_0, q_1\}, 0) \\ &= \{q_0, q_1, q_2\} \end{aligned}$$

q<sub>2</sub> is final state and the entire string has been consumed i.e., given string is accepted by NFA.

**Case ii)** Let  $w=1011 \notin L$

$$\begin{aligned} \delta(q_0, 1011) &= \delta(q_0, 011) \\ &= \delta(\{q_0, q_1\}, 11) \\ &= \delta(q_0, 1) \\ &= q_0 \end{aligned}$$

It is not final state and the entire string has been consumed i.e., given string is rejected by NFA.

**Step 6:** Represent NFA with tuples.

NFA,  $M = (\mathbf{Q}, \Sigma, \delta, \mathbf{q}_0, \mathbf{F})$

where  $Q = \{q_0, q_1, q_2\}$

$$\Sigma = \{0, 1\}$$

$$\delta: \delta(q_0, 0) = \{q_0, q_1\}$$

$$\delta(q_0, 1) = q_0$$

$$\delta(q_1, 0) = q_2$$

$$\delta(q_1, 1) = \emptyset$$

$$\delta(q_2, 0) = q_2$$

$$\delta(q_2, 1) = q_2$$

q<sub>0</sub> – initial state

F – final state =  $\{q_2\}$

**2. Design NFA that accepts strings which contains either two consecutive 0's or two consecutive 1's.**

**Step 1:** Understand the language for which the NFA has to be designed and write the language for the set of strings starting with minimum string that is accepted by FA.

$L = \{00, 11, 100, 001, 110, 011, 111, 000, 0100, 1011, \dots\}$

**Step 2:** Draw transition diagram for the minimum length string.

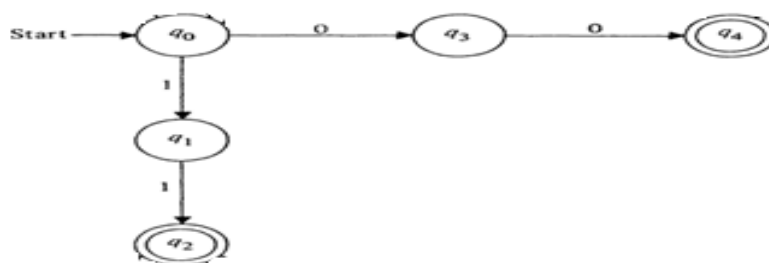

**Step 3:** Obtain the possible transitions to be made for each state on each input symbol.

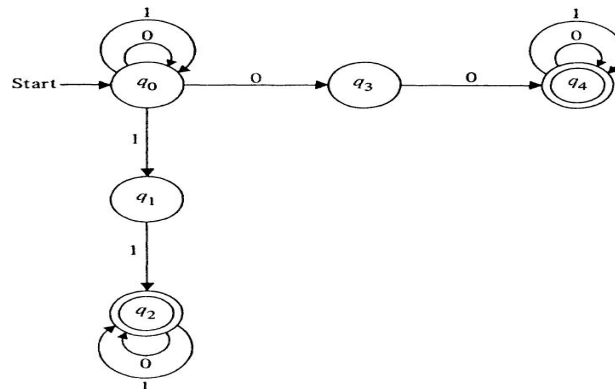

**Step 4:** Draw the transition table.

| State            | Input                              |                                    |
|------------------|------------------------------------|------------------------------------|
|                  | 0                                  | 1                                  |
| → q <sub>0</sub> | {q <sub>0</sub> , q <sub>3</sub> } | {q <sub>0</sub> , q <sub>1</sub> } |
| q <sub>1</sub>   | -                                  | q <sub>2</sub>                     |
| ⊙ q <sub>2</sub> | q <sub>2</sub>                     | q <sub>2</sub>                     |

|                |                |                |
|----------------|----------------|----------------|
| q <sub>3</sub> | q <sub>4</sub> | -              |
| q <sub>4</sub> | q <sub>4</sub> | q <sub>4</sub> |

**Step 5:** Test NFA with few strings that are accepted and few strings that are rejected by the given language.

**Case i)** Let the input,  $w = 01001 \in L$

$$\delta(q_0, 0) = \{q_0, q_3\}$$

$$\delta(q_0, 01) = \delta(\delta(q_0, 0), 1) = \delta(\{q_0, q_3\}, 1) = \delta(q_0, 1) \cup \delta(q_3, 1) = \{q_0, q_1\}$$

Similarly, we compute

$$\delta(q_0, 010) = \{q_0, q_3\}, \quad \delta(q_0, 0100) = \{q_0, q_3, q_4\}$$

and

$$\delta(q_0, 01001) = \{q_0, q_1, q_4\}$$

↘ final state

After the entire string is consumed, the FA is in state  $q_4$ . As  $q_4$  is the final state, the string is accepted by FA

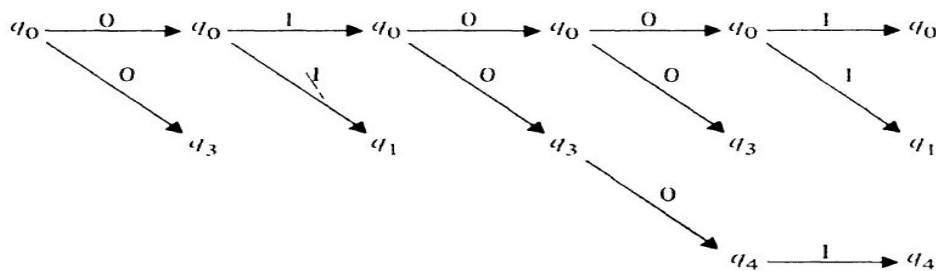

**Case ii)** Let  $w = 010 \notin L$

$$\begin{aligned} \delta(q_0, 010) &= \delta(\{q_0, q_3\}, 10) \\ &= \delta(\{q_0, q_1\}, 0) \\ &= \{q_0, q_3\} \end{aligned}$$

There is no path to the final state after the entire string is consumed. So the string is rejected by FA.

**Step 6:** Represent NFA with tuples.

NFA,  $M = (\mathbf{Q}, \Sigma, \delta, q_0, \mathbf{F})$

where  $Q = \{q_0, q_1, q_2, q_3, q_4\}$

$$\Sigma = \{0, 1\}$$

$$\delta: \delta(q_0, 0) = \{q_0, q_3\}$$

$$\delta(q_0, 1) = \{q_0, q_1\}$$

$$\delta(q_1, 0) = \emptyset$$

$$\delta(q_1, 1) = q_2$$

$$\delta(q_2, 0) = q_2$$

$$\delta(q_2, 1) = q_2$$

$$\delta(q_3, 0) = q_4$$

$$\delta(q_3, 1) = \emptyset$$

$$\delta(q_4, 0) = q_4$$

$$\delta(q_4, 1) = q_4$$

$q_0$  – initial state

$F$  – final state =  $\{q_2, q_4\}$

### **1.10 Language recognizers:**

A language recognizer is a device that accepts valid strings produced in a given language. Finite state automata are formalized types of language recognizers.

The language accepted by Finite Automata  $M$  designated  $L(M)$  is the set  $\{x \mid \delta(q_0, x) \text{ is in } F\}$ .

### **1.11 Applications of FA:**

- Used in Lexical analysis phase of a compiler to recognize tokens.
- Used in text editors for string matching.
- Software for designing and checking the behavior of digital circuits.

### **1.12 Limitations of FA:**

- FA's will have finite amount of memory.
- The class of languages recognized by FA's is strictly the regular set. There are certain languages which are non regular i.e. cannot be recognized by any FA.

### **1.13 Differences between NFA and DFA:**

| S.No | NFA  | DFA  |
|------|--|--|
| 1    | A nondeterministic finite automaton is a 5-tuple $M = (Q, \Sigma, \delta, q_0, F)$ , where $\delta: Q \times \Sigma \text{ into } 2^Q$ . | A deterministic finite automaton can be represented by a 5-tuple $M = (Q, \Sigma, \delta, q_0, F)$ , where $\delta: Q \times \Sigma \text{ to } Q$ . |
| 2    | NFA is the one in which there exists many paths for a specific input from current state to next state.                                   | DFA is a FA in which there is only one path for a specific input from current state to next state.   |
| 3    | NFA is easier to construct.  | DFA is more difficult to construct.  |
| 4    | NFA requires less space.   | DFA requires more space.   |
| 5    | Time required for executing an input string is more.   | Time required for executing an input string is less.   |



**UNIT - I****Assignment-Cum-Tutorial Questions****SECTION-A****Objective Questions**

- The prefix of abc is [     ]  
A) c                      B) bc                      C) b                      D)  $\epsilon$
- $\Sigma^* = \Sigma^+ \cup \epsilon$  [True | False]
- Alphabet is \_\_\_\_\_. [     ]  
A) Finite collection of strings.                      B) Finite collection of symbols.  
C) Finite collection of languages.                      D) All the above.
- A \_\_\_\_\_ of a string S is any trailing contiguous part of symbols of S.
- \_\_\_\_\_ is a directed graph associated with an FA in which the vertices of the graph correspond to the states of the FA.
- The transition function for NFA is a mapping function given as \_\_\_\_\_.
- The transition function for DFA is a mapping function given as \_\_\_\_\_.
- $A = \{a, b, c\}$ . Power set of A= \_\_\_\_\_
- FA has [     ]  
A) Unlimited memory                      B) no memory at all  
C) Limited memory                      D) none of the above.
- Number of states requires to accept string ends with 10. [     ]  
A) 3                      B) 2                      C) 1                      D) can't be represented.
- Consider the finite automaton in the following figure

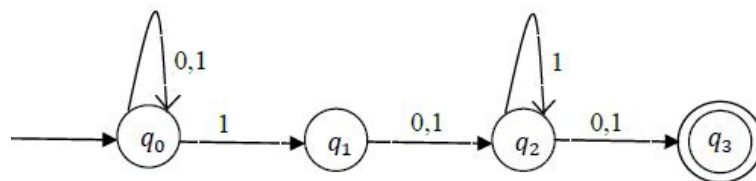

What is the set of reachable states for the input string 0011? [     ]

- A)  $\{q_0, q_1, q_2\}$       B)  $\{q_0, q_1\}$       C)  $\{q_0, q_1, q_2, q_3\}$       (D)  $\{q_3\}$

12. Given the language  $L = \{ab, aa, baa\}$ , which of the following strings are in  $L^*$ ?

- 1) abaabaaabaa      2) aaaabaaaa  
 3) baaaaabaaaab      4) baaaaabaa      [      ]  
 A) 1,2 and 3      B) 2,3 and 4      C) 1,2 and 4      D) 1, 3 and 4

13. In the automaton below, s is the start state and t is the only final state.

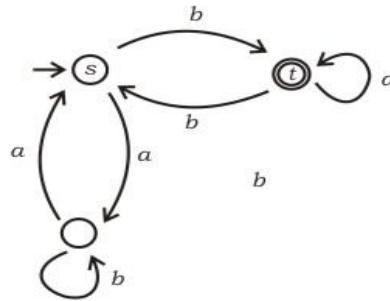

Consider the strings  $u = abbaba$ ,  $v = bab$ , and  $w = aabb$ . Which of the following statements is true? [      ]

- A) The automaton accepts  $u$  and  $v$  but not  $w$   
 B) The automaton accepts each of  $u, v$  and  $w$   
 C) The automaton rejects each of  $u, v$  and  $w$   
 D) The automaton accepts  $u$  but rejects  $v$  and  $w$
14. If the final states and non-final states in the DFA below are interchanged, then which of the following languages over the alphabet  $\{a, b\}$  will be accepted by the new DFA? [      ]

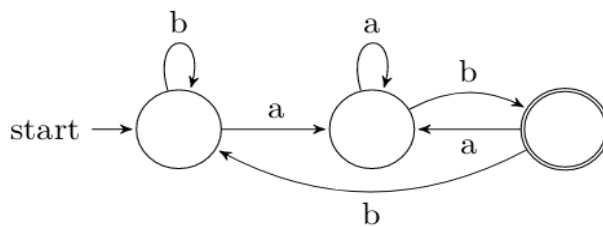

- A) Set of all strings that do not end with  $ab$   
 B) Set of all strings that begin with either an  $a$  or a  $b$   
 C) Set of all strings that do not contain the substring  $ab$ ,  
 D) All the above
15. The smallest finite automaton which accepts the language  $\{x \mid \text{length of } x \text{ is divisible by } 3\}$  has [      ]  
 A) 2 states      B) 3 states      C) 4 states      D) 5 states
16. The below DFA accepts the set of all strings over  $\{0, 1\}$  that [      ]

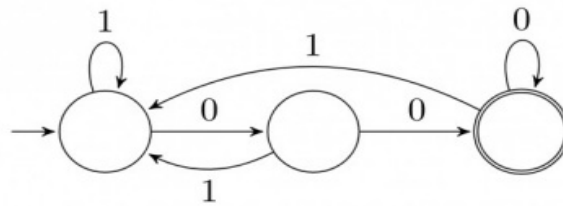

- A) begin either with 0 or 1                      B) end with 0  
 C) end with 00                                      D) contain the substring 00
17. Consider a DFA over  $\Sigma=\{a,b\}$  accepting all strings which have number of a's divisible by 6 and number of b's divisible by 8. What is the number of states that the DFA will have? [     ]  
 A) 8                      B) 14                      C) 15                      D) 48
18. What is the minimum number of states in the NFA accepting the language  $\{a, ab\}$  ? [     ]  
 A) 3                      B) 2                      C) 1                      D) 4
19. What is the number of states in NFA which accepts set of all strings in which the third last symbol is 'a' over alphabet  $\{a, b\}$ ? [     ]  
 A) three                      B) four                      C) six                      D) five

## SECTION-B

### Descriptive Questions:

- Define (i) String (ii) Alphabet (iii) Language (iv) Closure (v) Powerset
- Explain in detail various operations performed on Strings and Languages.
- Define i) Positive Closure ii) Kleene Closure.
- Define Finite Automaton(FA). Explain in detail different ways to represent it.
- Sketch and explain in detail the model of FA. Give its tuple notation.
- Differentiate between NFA and DFA.
- What is the difference between empty language and null string?
- Which of the following Finite Automaton is having ambiguity and why?  
 i) NFA                      ii) DFA
- Draw the Finite state machine for accepting the languages  $\square$  and  $\emptyset$ .
- Draw Transition diagram for the Transition table given below and check acceptance for the strings:  
 i) 1000101                      ii) 011001

|      |    |    |
|------|----|----|
|      | 0  | 1  |
| → q0 | q1 | q0 |
| q1   | q2 | q0 |
| q2   | q3 | q0 |
| ⊙ q3 | q3 | q3 |

11. Draw the transition diagram for below FA:

$$M = \{ \{A, B, C, D\}, \{0, 1\}, \delta, C, \{A, C\} \}$$

$$\delta(A, 0) = \delta(A, 1) = \{A, B, C\}$$

$$\delta(B, 0) = B, \delta(B, 1) = \{A, C\}$$

$$\delta(C, 0) = \{B, C\}, \delta(C, 1) = \{B, D\}$$

$$\delta(D, 0) = \{A, B, C, D\}$$

$$\delta(D, 1) = \{A\}.$$

12. Construct DFA accepting the set of all strings beginning with 101.  
 13. Design a DFA for a language which contains strings of a's & b's and each string ends with aab.  
 14. Describe the words  $w$  in the language  $L$  accepted by the automaton in

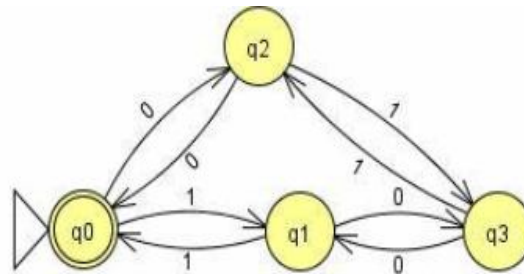

15. Design a DFA that accepts set of all strings with abab as a substring over alphabet  $\{a, b\}$ .  
 16. Design a DFA that accepts set of all strings with three consecutive 0's over alphabet  $\{0, 1\}$ .  
 17. Design a DFA that accepts all strings over  $\Sigma = \{0, 1\}$  that do not contain 101 as a substring.  
 18. Obtain a DFA to accept strings of a's and b's such that, each block of 5 consecutive symbols has at least two a's.  
 19. a) Design a DFA to accept the following language.  $L = \{w \mid |w| \bmod 3 = 0\}$  on  $\Sigma = \{a\}$   
 b) Design DFA accepting the language whose binary interpretation is divisible by 5 over the alphabet  $\{0, 1\}$ .  
 20. Design a DFA that accepts set of all strings in which number of a's is divisible by 4 over alphabet  $\{0, 1\}$ .

21. Design a DFA to accept strings of a's and b's having even number of a's and b's.
22. For the NFA given below;
- Check whether the string axxaxxa is accepted or not
  - Give atleast two transition paths

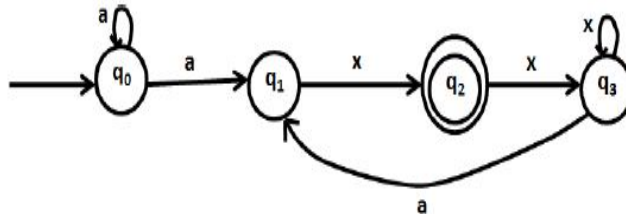

23. Design DFA accepting the set of all strings that begin with 01 and end with 11.
24. Design NFA accepting the set of all strings that begins with abb over alphabet {a, b}.
25. Design a NFA that accepts set of all strings with aba as a substring over alphabet {a, b}.
26. Design a NFA to accept strings of 0's & 1's such that each string ends with 00.

### SECTION-C

#### Gate Questions:

1. Consider the following Deterministic Finite Automata [GATE 2017]

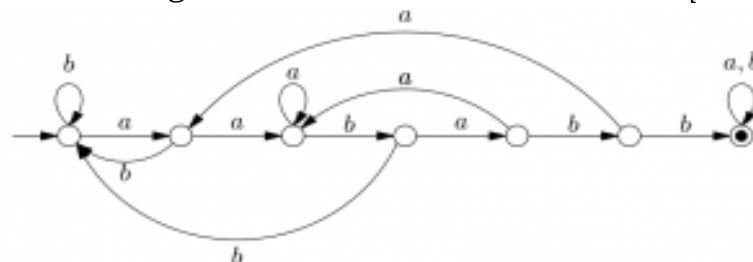

Which of the following is true? [ ]

- It only accepts strings with prefix as "aababb"
  - It only accepts strings with substring as "aababb"
  - It only accepts strings with suffix as "aababb"
  - None of the above
2. The possible number of states of a deterministic finite automaton that accepts a regular language. [GATE 2017]

$$L = \{w_1aw_2 \mid w_1, w_2 \in \{a, b\}^*, |w_1| = 2, |w_2| \geq 3\} \text{ is}$$

3. Let  $w$  be any string of length  $n$  in  $\{0, 1\}^*$ . Let  $L$  be the set of all substrings of  $w$ . What is the number of states in a non-deterministic finite

automaton that accepts L? [ ]  
 [GATE 2010]

- A)  $n-1$
- B)  $n$
- C)  $n+1$
- D)  $2n-1$

4. Consider the machine M:

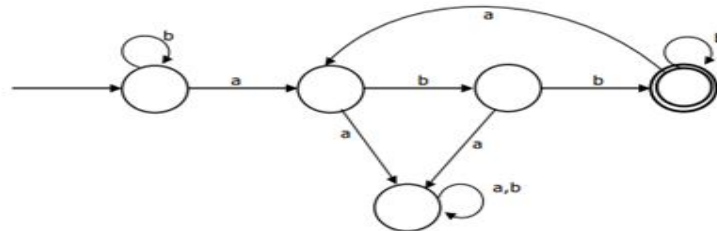

[GATE 2005]

The language recognized by M is: [ ]

- A)  $\{w \in \{a,b\}^* \mid \text{every } a \text{ in } w \text{ is followed by exactly two } b\text{'s}\}$
- B)  $\{w \in \{a,b\}^* \mid \text{every } a \text{ in } w \text{ is followed by at least two } b\text{'s}\}$
- C)  $\{w \in \{a,b\}^* \mid w \text{ contains the substring 'abb'}\}$
- D)  $\{w \in \{a,b\}^* \mid w \text{ does not contain 'aa' as a substring}\}$

5. The following finite state machine accepts all those binary strings in which the number of 1's and 0's are respectively [ ]

[GATE 2004]

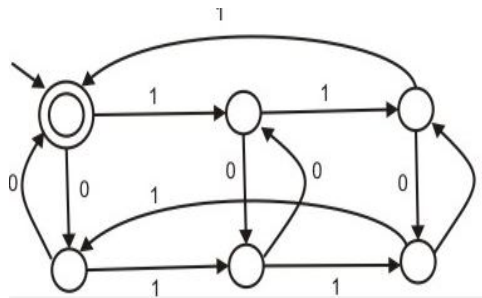

- A) divisible by 3 and 2
  - B) odd and even
  - C) even and odd
  - D) divisible by 2 and 3
6. Consider the following deterministic finite state automaton M

[GATE 2003]

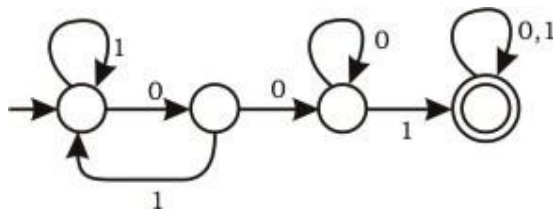

Let S denote the set of seven bit binary strings in which the first, the fourth, and the last bits are 1. The number of strings in S that are accepted by M is

- A) 1                      B) 5                      C) 7                      D) 8 [     ]
7. Consider the NFA M shown below.

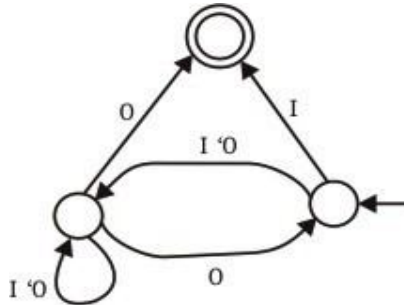

Let the language accepted by M be L. Let L1 be the language accepted by the NFA M1, obtained by changing the accepting state of M to a non-accepting state and by changing the non-accepting state of M to accepting states. Which of the following Statements is true? [     ]

[GATE 2003]

- A)  $L1 = \{0,1\}^* - L$                       B)  $L1 = \{0,1\}^*$                       C)  $L1 \subseteq L$                       D)  $L1 = L$
8. Construct a finite state machine that accepts the language, over  $\{0,1\}$ , of all strings that contain neither the substring 00 nor the substring 11. [GATE 2000]

9. What can be said about a regular language L over  $\{a\}$  whose minimal finite state automaton has two states? [     ]

[GATE 2000]

- A) L must be  $\{a^n \mid n \text{ is odd}\}$   
 B) L must be  $\{a^n \mid n \text{ is even}\}$   
 C) L must be  $\{a^n \mid n \geq 0\}$   
 D) Either L must be  $\{a^n \mid n \text{ is odd}\}$ , or L must be  $\{a^n \mid n \text{ is even}\}$

## UNIT – II

### **Objective:**

To familiarize how to employ non-deterministic finite automata with  $\epsilon$  transitions and finite automata with outputs.

### **Syllabus:**

#### **Finite Automata:**

NFA with  $\epsilon$  transitions - significance, acceptance of languages, equivalence between NFA with and without  $\epsilon$  transitions, NFA to DFA conversion, minimization of FSM, equivalence between two FSM's, finite automata with output-Moore and Mealy machines, applications of FA.

### **Learning Outcomes:**

Students will be able to:

- Convert NFA to DFA and NFA with epsilon transitions to NFA without Epsilon transitions.
- Minimize the given DFA.
- Test whether the two DFA's are equivalent or not.
- Design Moore and Mealy Machines

## 2.Learning Material

### 2.1 NFA with $\epsilon$ transitions:

An  $\epsilon$ -NFA is a tuple  $(Q, \Sigma, \delta, q_0, F)$

where

- $Q$  is a set of states,
- $\Sigma$  is the alphabet,
- $\delta$  is the transition function that maps each pair consisting of a state and a symbol in  $\Sigma \cup \{\epsilon\}$  to a subset of  $Q$ ,
- $q_0$  is the initial state,
- $F \subset Q$  is the set of final (or accepting) states.



**2.2 Significance of  $\epsilon$ -NFA:**

It becomes very difficult or many times it seems to be impossible to draw directly NFA or DFA.

**Example:**

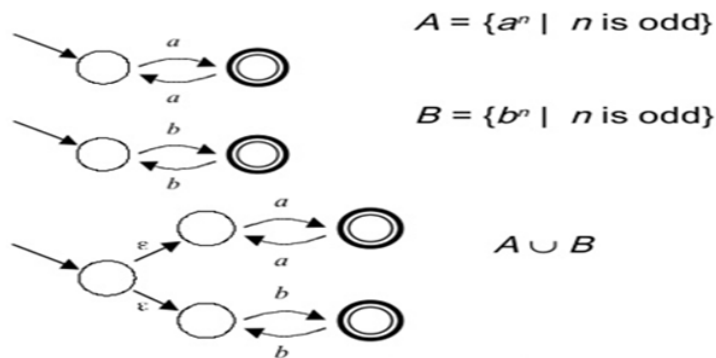
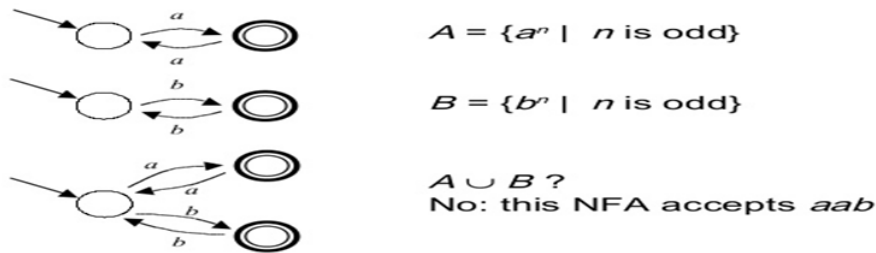

**2.3 String acceptance by  $\epsilon$ -NFA**

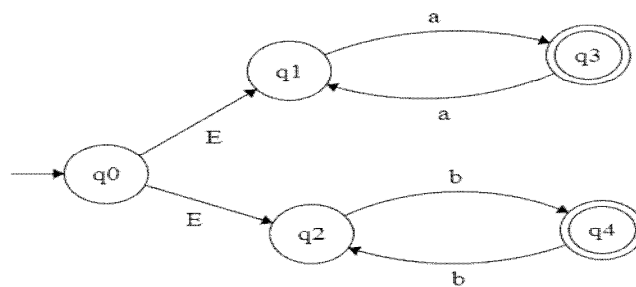

**Fig:1**

**Transition Table:**

| $Q/\Sigma$ | a | b | $\epsilon$     |
|------------|---|---|----------------|
| $q_0$      | - | - | $\{q_1, q_2\}$ |

|                      |                      |                      |   |
|----------------------|----------------------|----------------------|---|
| <b>q<sub>1</sub></b> | <b>q<sub>3</sub></b> | -                    | - |
| <b>q<sub>2</sub></b> | -                    | <b>q<sub>4</sub></b> | - |
| <b>q<sub>3</sub></b> | <b>q<sub>1</sub></b> | -                    | - |
| <b>q<sub>4</sub></b> | -                    | <b>q<sub>2</sub></b> | - |

**Example:**

**Check whether the string 'bbb' is accepted or not for the above automaton.**

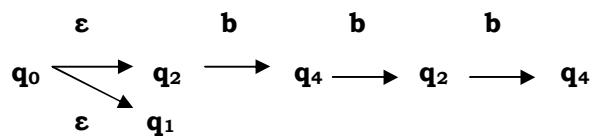

As q<sub>4</sub> is the final state, the given string is accepted by the given ε-NFA.

**2. 4 ε -NFA to NFA Conversion:**

**Step 1:** Find the ε-closure for all states in the given ε-NFA.

$$\hat{\delta}(q, \epsilon) = \epsilon\text{-CLOSURE}(q)$$

ε-closure (q) denotes the set of all states p such that there is a path from q to p labelled ε.

**Step 2:** Find the extended transition function for all states on all input symbols for the given ε-NFA.

$$\delta'(q, a) = \epsilon\text{-closure}(\delta(\delta'(q, \epsilon), a))$$

**Step 3:** Draw the transition table or diagram from the extended transition function (NFA)

**Step 4:** F is the set of final states of NFA, whose ε -closure contains the final state of ε -NFA.

**Step 5:** To check the equivalence of  $\epsilon$ -NFA and NFA, the string accepted by  $\epsilon$ -NFA should be accepted by NFA.

**Example:**

**1. Convert NFA with  $\epsilon$ -moves into an equivalent NFA without  $\epsilon$ -moves.**

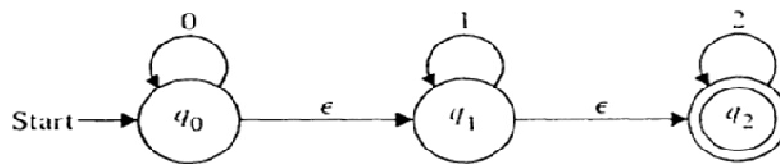

**Finite automaton with  $\epsilon$ -moves.**

**Step 1:** Find the  $\epsilon$ -closure for all states in the given  $\epsilon$ -NFA.

$$\epsilon\text{-CLOSURE}(q_0) = \{q_0, q_1, q_2\}$$

$$\epsilon\text{-CLOSURE}(q_1) = \{q_1, q_2\}$$

$$\epsilon\text{-CLOSURE}(q_2) = \{q_2\}$$

**Step 2:** Find the extended transition function for all states on all input symbols for the given  $\epsilon$ -NFA.

$$\begin{aligned} \delta'(q_0, 0) &= \epsilon\text{-closure}(\delta(\delta'(q_0, \epsilon), 0)) \\ &= \epsilon\text{-closure}(\delta(\{q_0, q_1, q_2\}, 0)) \\ &= \epsilon\text{-closure}(\delta(q_0, 0) \cup \delta(q_1, 0) \cup \delta(q_2, 0)) \\ &= \epsilon\text{-closure}(q_0 \cup \emptyset \cup \emptyset) \\ &= \{q_0, q_1, q_2\} \end{aligned}$$

$$\begin{aligned} \delta'(q_0, 1) &= \epsilon\text{-closure}(\delta(\delta'(q_0, \epsilon), 1)) \\ &= \epsilon\text{-closure}(\delta(\{q_0, q_1, q_2\}, 1)) \\ &= \epsilon\text{-closure}(\delta(q_0, 1) \cup \delta(q_1, 1) \cup \delta(q_2, 1)) \\ &= \epsilon\text{-closure}(\emptyset \cup q_1 \cup \emptyset) \\ &= \{q_1, q_2\} \end{aligned}$$

$$\begin{aligned} \delta'(q_0, 2) &= \epsilon\text{-closure}(\delta(\delta'(q_0, \epsilon), 2)) \\ &= \epsilon\text{-closure}(\delta(\{q_0, q_1, q_2\}, 2)) \\ &= \epsilon\text{-closure}(\delta(q_0, 2) \cup \delta(q_1, 2) \cup \delta(q_2, 2)) \\ &= \epsilon\text{-closure}(q_2 \cup \emptyset) \\ &= \{q_2\} \end{aligned}$$

$$\begin{aligned}\delta'(q_1, 0) &= \varepsilon\text{-closure}(\delta(\delta'(q_1, \varepsilon), 0)) \\ &= \varepsilon\text{-closure}(\delta\{q_1, q_2\}, 0) \\ &= \varepsilon\text{-closure}(\delta(q_1, 0) \cup \delta(q_2, 0)) \\ &= \varepsilon\text{-closure}(\emptyset) \\ &= \{\emptyset\}\end{aligned}$$

$$\begin{aligned}\delta'(q_1, 1) &= \varepsilon\text{-closure}(\delta(\delta'(q_1, \varepsilon), 1)) \\ &= \varepsilon\text{-closure}(\delta\{q_1, q_2\}, 1) \\ &= \varepsilon\text{-closure}(\delta(q_1, 1) \cup \delta(q_2, 1)) \\ &= \varepsilon\text{-closure}(q_1) \\ &= \{q_1, q_2\}\end{aligned}$$

$$\begin{aligned}\delta(q_1, 2) &= \varepsilon\text{-closure}(\delta(\delta'(q_1, \varepsilon), 2)) \\ &= \varepsilon\text{-closure}(\delta\{q_1, q_2\}, 2) \\ &= \varepsilon\text{-closure}(\delta(q_1, 2) \cup \delta(q_2, 2)) \\ &= \varepsilon\text{-closure}(q_2) \\ &= \{q_2\}\end{aligned}$$

$$\begin{aligned}\delta(q_2, 0) &= \varepsilon\text{-closure}(\delta(\delta'(q_2, \varepsilon), 0)) \\ &= \varepsilon\text{-closure}(\delta(q_2, 2)) \\ &= \varepsilon\text{-closure}(\emptyset) \\ &= \{\emptyset\}\end{aligned}$$

$$\begin{aligned}\delta(q_2, 1) &= \varepsilon\text{-closure}(\delta(\delta'(q_2, \varepsilon), 1)) \\ &= \varepsilon\text{-closure}(\delta(q_2, 1)) \\ &= \varepsilon\text{-closure}(\emptyset) \\ &= \{\emptyset\}\end{aligned}$$

$$\begin{aligned}\delta(q_2, 2) &= \varepsilon\text{-closure}(\delta(\delta'(q_2, \varepsilon), 2)) \\ &= \varepsilon\text{-closure}(\delta(q_2, 2)) \\ &= \varepsilon\text{-closure}(q_2) \\ &= \{q_2\}\end{aligned}$$

**Step 3:** Draw the transition table or diagram from the extended transition function (NFA)

| State            | Inputs  |                                    |                |
|------------------|---|------------------------------------|----------------|
|                  | 0   | 1                                  | 2              |
| → q <sub>0</sub> | {q <sub>0</sub> , q <sub>1</sub> , q <sub>2</sub> } | {q <sub>1</sub> , q <sub>2</sub> } | q <sub>2</sub> |
| q <sub>1</sub>   | ∅   | {q <sub>1</sub> , q <sub>2</sub> } | q <sub>2</sub> |
| *q <sub>2</sub>  | ∅   | ∅                                  | q <sub>2</sub> |

**Step 4:** F is the set of final states of NFA, whose  $\epsilon$ -closure contains the final state of  $\epsilon$ -NFA.

| State               | Inputs  |                                    |                |
|---------------------|---|------------------------------------|----------------|
|                     | 0   | 1                                  | 2              |
| → (q <sub>0</sub> ) | {q <sub>0</sub> , q <sub>1</sub> , q <sub>2</sub> } | {q <sub>1</sub> , q <sub>2</sub> } | q <sub>2</sub> |
| (q <sub>1</sub> )   | ∅   | {q <sub>1</sub> , q <sub>2</sub> } | q <sub>2</sub> |
| (q <sub>2</sub> )   | ∅   | ∅                                  | q <sub>2</sub> |

**Step 5:** To check the equivalence of  $\epsilon$ -NFA and NFA, the string accepted by  $\epsilon$ -NFA should be accepted by NFA.

**String acceptance by  $\epsilon$ -NFA:**

Let w=001

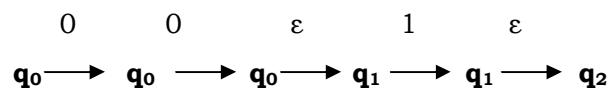

As q<sub>2</sub> is the final state, the string is accepted by the given  $\epsilon$ -NFA.

**String acceptance by NFA:**

If w=001

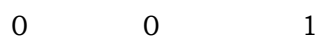

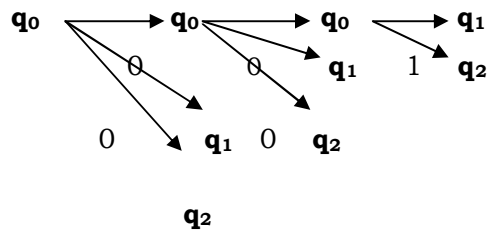

As  $q_1$  and  $q_2$  are final states, the string is accepted by the NFA.

### 2.5 NFA to DFA Conversion:

**Step 1:** First take the starting state of NFA as the starting state of DFA.

**Step 2:** Apply the inputs on initial state and represent the corresponding states in the transition table.

**Step 3:** For each newly generated state, apply the inputs and represent the corresponding states in the transition table.

**Step 4:** Repeat step 3 until no more new states are generated.

**Step 5:** The states which contain any of the final states of the NFA are the final states of the equivalent DFA.

**Step 6:** Represent the transition diagram from the constructed table.

**Step 7:** To check the equivalence of NFA and DFA, the string accepted by NFA should be accepted by DFA.

**Step 8:** Write the tuple representation for the obtained DFA.

**Note:** If the NFA has  $n$  states, the resulting DFA may have up to  $2^n$  states, an exponentially larger number, which sometimes makes the construction impractical for large NFAs.

#### **Example:**

1. Construct DFA equivalent to the NFA  $M = (\{q_0, q_1\}, \{0, 1\}, \delta, q_0, \{q_1\})$

where  $\delta(q_0, 0) = \{q_0, q_1\}$        $\delta(q_0, 1) = \{q_1\}$        $\delta(q_1, 0) = \emptyset$        $\delta(q_1, 1) = \{q_0, q_1\}$

**Step 1:** First take the starting state of NFA as the starting state of DFA

| $Q/\Sigma$ | <b>0</b> | <b>1</b> |
|------------|----------|----------|
| $[q_0]$    |          |          |

**Step 2:** Apply the inputs on initial state and represent the corresponding states in the transition table.

| $Q/\Sigma$ | <b>0</b>     | <b>1</b> |
|------------|--------------|----------|
| $[q_0]$    | $[q_0, q_1]$ | $[q_1]$  |

**Step 3:** For each newly generated state, apply the inputs and represent the corresponding states in the transition table.

| $Q/\Sigma$   | <b>0</b>     | <b>1</b>     |
|--------------|--------------|--------------|
| $[q_0]$      | $[q_0, q_1]$ | $[q_1]$      |
| $[q_0, q_1]$ | $[q_0, q_1]$ | $[q_0, q_1]$ |
| $[q_1]$      | $\emptyset$  | $[q_0, q_1]$ |

**Step 4:** Stop the procedure as there are no more new states being generated.

**Step 5:** The states which contain any of the final states of the NFA are the final states of the equivalent DFA.

$q_1$  is the final state in NFA.  $q_1$  is included in the state  $[q_0, q_1]$  and  $[q_1]$ . So  $[q_0, q_1]$  and  $[q_1]$  are the final states of the DFA.

| $Q/\Sigma$   | <b>0</b>     | <b>1</b>     |
|--------------|--------------|--------------|
| $[q_0]$      | $[q_0, q_1]$ | $[q_1]$      |
| $[q_0, q_1]$ | $[q_0, q_1]$ | $[q_0, q_1]$ |
| $[q_1]$      | $\emptyset$  | $[q_0, q_1]$ |

**Step 6:** Represent the transition diagram from the constructed table.

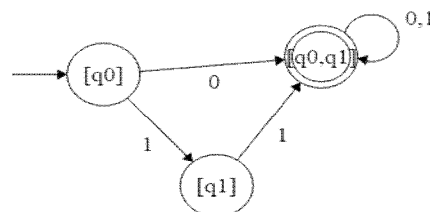

**Step 7:** To check the equivalence of NFA and DFA, the string accepted by NFA should be accepted by DFA.

Let  $w=1110$  be the string accepted by NFA.

**Acceptability by NFA:**

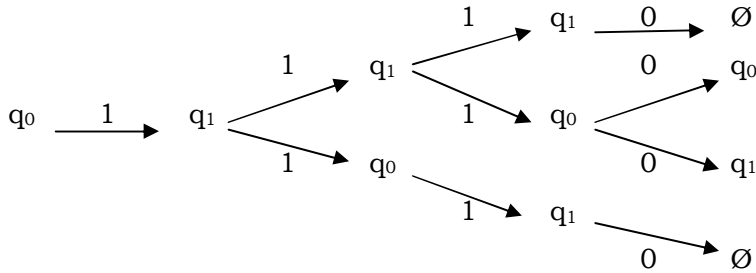

**Acceptability by DFA:**

$$\begin{aligned}
 \delta([q_0], 1110) &= \delta([q_1], 110) && [q_0] \xrightarrow{1} [q_1] \xrightarrow{1} [q_0, q_1] \xrightarrow{1} [q_0, q_1] \xrightarrow{0} [q_0, q_1] \\
 &= \delta([q_0, q_1], 10) \\
 &= \delta([q_0, q_1], 0) \\
 &= [q_0, q_1] \notin F
 \end{aligned}$$

**Step 8:** Write the tuple representation from the obtained DFA.

DFA  $M' = (Q, \Sigma, \delta, q_0, F)$

where  $Q = \{[q_0], [q_0, q_1], [q_1]\}$

$\Sigma = \{0, 1\}$

$\delta$  - transition function

$[q_0]$  - initial state

$F = \{[q_0], [q_0, q_1]\}$

**2.6 Minimization of Finite Automata:**

Two states  $q_1$  and  $q_2$  are equivalent (denoted by  $q_1 \equiv q_2$ ) if both  $\delta(q_1, x)$  and  $\delta(q_2, x)$  are final states. or both of them are nonfinal states for all  $x \in \Sigma^*$ .



Two states  $q_1$  and  $q_2$  are  $k$ -equivalent ( $k \geq 0$ ) if both  $\delta(q_1, x)$  and  $\delta(q_2, x)$  are final states or both nonfinal states for all strings  $x$  of length  $k$  or less. In particular, any two final states are 0-equivalent and any two nonfinal states are also 0-equivalent.

**Construction of Minimum Automaton:**

**Step 1:** (Construction of  $\pi_0$ )· By definition of 0-equivalence,  $\pi_0 = \{Q_1^0, Q_2^0\}$  where  $Q_1^0$  is the set of all final states and  $Q_2^0 = Q - Q_1^0$ .

**Step 2:** (Construction of  $\pi_{k+1}$  from  $\pi_k$ ).

- Let  $Q_i^k$  be any subset in  $\pi_k$ . If  $q_1$  and  $q_2$  are in  $Q_i^k$ , they are  $(k + 1)$ -equivalent provided  $\delta(q_1, a)$  and  $\delta(q_2, a)$  are  $k$ -equivalent.
- Find out whether  $\delta(q_1, a)$  and  $\delta(q_2, a)$  are in the same equivalence class in  $\pi_k$  for every  $a \in \Sigma$ . If so  $q_1$  and  $q_2$  are  $(k + 1)$ -equivalent.
- In this way,  $Q_i^k$  is further divided into  $(k + 1)$ -equivalence classes. Repeat this for every  $Q_i^k$  in  $\pi_k$  to get all the elements of  $\pi_{k+1}$ .

**Step 3:** Construct  $\pi_n$  for  $n = 1, 2, \dots$  until  $\pi_n = \pi_{n+1}$ .

**Step 4:** (Construction of minimum automaton). For the required minimum state automaton, the states are the equivalence classes obtained in step 3. i.e. the elements of  $\pi_n$ . The state table is obtained by replacing a state  $q$  by the corresponding equivalence class  $[q]$ .

**Example:**

Construct a minimum state automaton equivalent to the finite automaton.

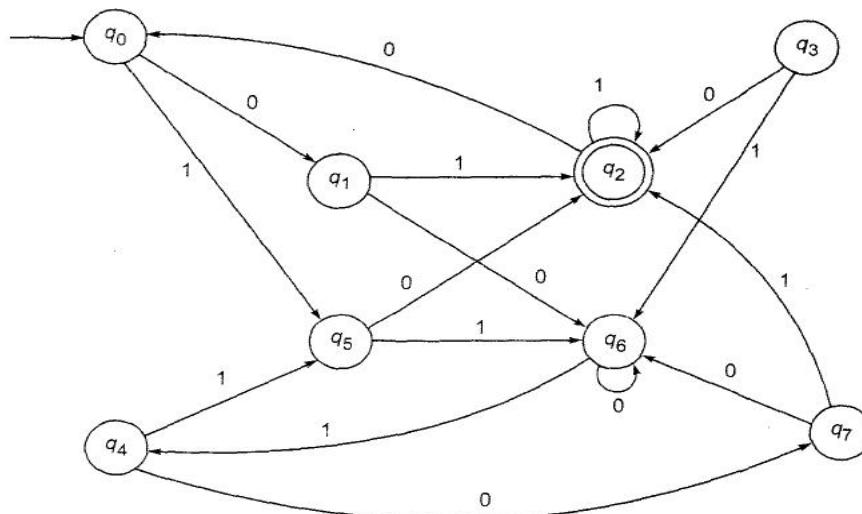

**Solution:**

It will be easier if we construct the transition table.

| State/ $\Sigma$   | 0     | 1     |
|-------------------|-------|-------|
| $\rightarrow q_0$ | $q_1$ | $q_5$ |
| $q_1$             | $q_6$ | $q_2$ |
| $q_2$             | $q_0$ | $q_2$ |
| $q_3$             | $q_2$ | $q_6$ |
| $q_4$             | $q_7$ | $q_5$ |
| $q_5$             | $q_2$ | $q_6$ |
| $q_6$             | $q_6$ | $q_4$ |
| $q_7$             | $q_6$ | $q_2$ |

**Step 1:** Construction of  $\pi_0$ 

$$\pi_0 = \{Q_1^0, Q_2^0\}$$

$$\text{where } Q_1^0 = F = \{q_2\}$$

$$Q_2^0 = Q - Q_1^0$$

$$\therefore \pi_0 = \{\{q_2\}, \{q_0, q_1, q_3, q_4, q_5, q_6, q_7\}\}$$

**Step 2:** The  $\{q_2\}$  in  $\pi_0$  cannot be further partitioned. So,  $Q_1^1 = \{q_2\}$ .

Compare  $q_0$  with  $q_1, q_3, q_4, q_5, q_6$  and  $q_7$ .

Consider  $q_0$  and  $q_1 \notin Q_2^0$ .

- The entries under the 0- column corresponding to  $q_0$  and  $q_1$  are  $q_1$  and  $q_6$ ; they lie in  $Q_2^0$ .
- The entries under the 1-column are  $q_5$  and  $q_2$ .  $q_2 \in Q_1^0$  and  $q_5 \notin Q_2^0$ . Therefore  $q_0$  and  $q_1$  are not 1- equivalent.

| $Q/\Sigma$ | 0     | 1     |
|------------|-------|-------|
| $q_0$      | $q_1$ | $q_5$ |
| $q_1$      | $q_6$ | $q_2$ |

Consider  $q_0$  and  $q_3$

| $Q/\Sigma$ | 0     | 1     |
|------------|-------|-------|
| $q_0$      | $q_1$ | $q_5$ |

|       |       |       |
|-------|-------|-------|
| $q_3$ | $q_2$ | $q_6$ |
|-------|-------|-------|

The entries under the 0- column corresponding to  $q_0$  and  $q_3$  are  $q_1$  and  $q_2$ ;  $q_1 \in Q_2^0$  and  $q_2 \in Q_1^0$ . The entries under the 1-column are  $q_5$  and  $q_6$ ; they lie in  $Q_2^0$ . Therefore  $q_0$  and  $q_3$  are not 1- equivalent

Similarly,  $q_0$  is not 1-equivalent to  $q_5$  and  $q_7$ .

Consider  $q_0$  and  $q_4$

| $Q/\Sigma$ | 0     | 1     |
|------------|-------|-------|
| $q_0$      | $q_1$ | $q_5$ |
| $q_4$      | $q_7$ | $q_5$ |

- The entries under the 0- column corresponding to  $q_0$  and  $q_4$  are  $q_1$  and  $q_7$ ; they lie in  $Q_2^0$ .
- The entries under the 1-column are  $q_5$  and  $q_5$ ; they lie in  $Q_2^0$ . Therefore  $q_0$  and  $q_4$  are 1- equivalent.

Similarly,  $q_0$  is 1-equivalent to  $q_6$ .

$\{q_0, q_4, q_6\}$  is a subset in  $\pi_1$ .

So,  $Q_2^1 = \{q_0, q_4, q_6\}$

- Repeat the construction by considering  $q_1$  and anyone of the state's  $q_3, q_5, q_7$ . Now,  $q_1$  is not 1-equivalent to  $q_3$  or  $q_5$  but 1-equivalent to  $q_7$ .

Hence,  $Q_3^1 = \{q_1, q_7\}$ .

- The elements left over in  $Q_2^0$  are  $q_3$  and  $q_5$ . By considering the entries under the 0-column and the 1-column, we see that  $q_3$  and  $q_5$  are 1-equivalent.

So  $Q_4^1 = \{q_3, q_5\}$ .

Therefore,  $\pi_1 = \{\{q_2\}, \{q_0, q_4, q_6\}, \{q_1, q_7\}, \{q_3, q_5\}\}$

**Step 3:** Construct  $\pi_n$  for  $n = 1, 2, \dots$  until  $\pi_n = \pi_{n+1}$ .

Calculate 2-equivalent,  $\pi_2$ .

$\pi_2 = \{\{q_2\}, \{q_0, q_4\}, \{q_6\}, \{q_1, q_7\}, \{q_3, q_5\}\}$

Similarly calculate 3-equivalent,  $\pi_3$ .

$$\pi_3 = \{\{q_2\}, \{q_0, q_4\}, \{q_6\}, \{q_1, q_7\}, \{q_3, q_5\}\}$$

As  $\pi_2 = \pi_3, \pi_2$  gives us the equivalence classes.

**Step 4:** Construction of minimum automaton.

$$M' = (Q', \{0, 1\}, \delta', q_0', F')$$

where  $Q' = \{\{q_2\}, [q_0, q_4], [q_6], [q_1, q_7], [q_3, q_5]\}$

$$q_0' = [q_0, q_4]$$

$$F' = [q_2]$$

$\delta'$  is given by

| State/ $\Sigma$ | 0            | 1            |
|-----------------|--------------|--------------|
| $[q_0, q_4]$    | $[q_1, q_7]$ | $[q_3, q_5]$ |
| $[q_1, q_7]$    | $[q_6]$      | $[q_2]$      |
| $[q_2]$         | $[q_0, q_4]$ | $[q_2]$      |
| $[q_3, q_5]$    | $[q_2]$      | $[q_6]$      |
| $[q_6]$         | $[q_6]$      | $[q_0, q_4]$ |

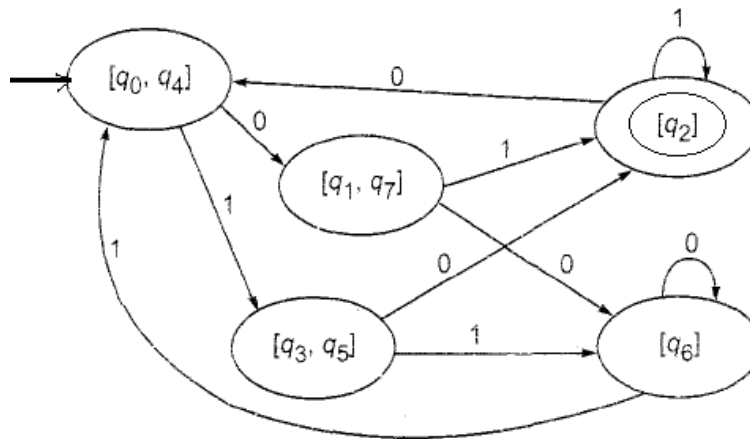

## 2.7 Equivalence between two FSM's:

Let  $M$  and  $M'$  be two FSM's over  $\Sigma$ . We construct a comparison table consisting of  $n+1$  columns where  $n$  is the number of input symbols.

**Step 1:** 1<sup>st</sup> column consisting of a pair of states of form  $(q, q')$  where  $q$  belongs to  $M$  and  $q'$  belongs to  $M'$ .

**Step 2:** If  $(q, q')$  appears in the same row of 1<sup>st</sup> column then the corresponding entry in a column (a belongs to  $\Sigma$ ) is  $(r, r')$  where  $(r, r')$  are pair from  $q$  and  $q'$  on  $a$ .

**Step 3:** A table is constructed by starting with a pair of initial states  $q_0, q_0'$  of  $M$  and  $M'$ . We complete construction by considering the pairs in 2<sup>nd</sup> and subsequent columns which are not in the 1<sup>st</sup> column.

(i) if we reach a pair  $(q, q')$  such that  $q$  is final states of  $M$  and  $q'$  is non-final state of  $M'$  i.e. terminate construction and conclude that  $M$  and  $M'$  are not equivalent.

(ii) if construction is terminated when no new element appears in 2<sup>nd</sup> and subsequent columns which are not in 1<sup>st</sup> column. Conclude that  $M$  and  $M'$  are equivalent.

**Example:**

Check whether the given two finite automata's are equivalent or not.

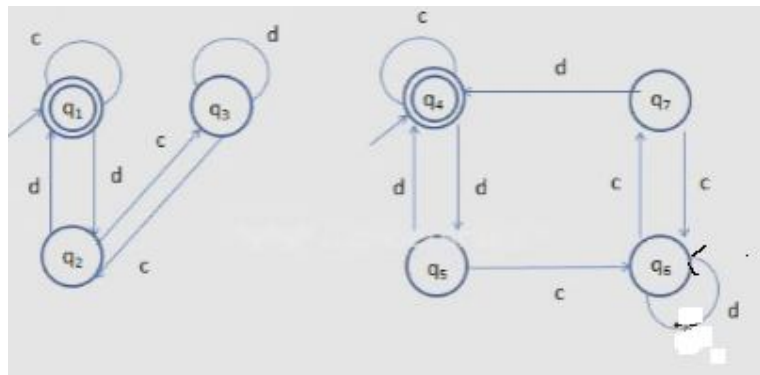

**Solution:**

$q_1$  is initial state of  $M_1$  and  $q_4$  is initial state of  $M_2$ , make them a pair and place it in 1<sup>st</sup> row of the transition table.

**Comparison table**

| $Q/\Sigma$                     | <b>c</b>                       | <b>d</b>                       |
|--------------------------------|--------------------------------|--------------------------------|
| <b>(<math>q_1, q_4</math>)</b> | <b>(<math>q_1, q_4</math>)</b> | <b>(<math>q_2, q_5</math>)</b> |
| <b>(<math>q_2, q_5</math>)</b> | <b>(<math>q_3, q_4</math>)</b> |                                |

Here  $q_3$  is non-final state and  $q_4$  is final state.

Therefore, we stop constructing comparison table and conclude that the two given Finite Automata's are not equivalent.

## 2.8 Moore Machine

**A Moore machine is a six tuple  $(Q, \Sigma, \Delta, \delta, q_0, \lambda)$**

where

- $Q$  is a set of states,
- $\Sigma$  is the alphabet,
- $\delta$  is the transition function that maps each pair consisting of a state and a symbol in  $\Sigma$  to  $Q$  i.e.  $Q \times \Sigma \rightarrow Q$
- $q_0$  is the initial state,
- $\Delta$  is output alphabet
- $\lambda$  is a mapping from  $Q$  to  $\Delta$  giving the output associated with each state

**Note:** For a Moore machine if the input string is of length  $n$ , the output string is of length  $n + 1$ . The first output is  $\lambda(q_0)$  for all output strings.

## 2.9 Mealy Machine

**A Mealy machine is a six tuple  $(Q, \Sigma, \Delta, \delta, q_0, \lambda)$**

where

- $Q$  is a set of states,
- $\Sigma$  is the alphabet,
- $\delta$  is the transition function that maps each pair consisting of a state and a symbol in  $\Sigma$  to  $Q$  i.e.  $Q \times \Sigma \rightarrow Q$
- $\Delta$  is output alphabet
- $q_0$  is the initial state,
- $\lambda$  maps  $Q \times \Sigma$  to  $\Delta$  i.e.,  $\lambda(q,a)$  gives the output associated with the transition from state  $q$  on input  $a$

**Note:** In the case of a Mealy machine if the input string is of length  $n$ , the output string is also of the same length  $n$ .

### **Example:**

- The given transition diagram is moore machine because each state is associated with output.
- In the below diagram  $q_0$  is representing 0 output,  $q_1$  is is representing 1 output and  $q_2$  is representing 2 output.

$$\lambda(q_0) = 0 \quad \lambda(q_1) = 1 \quad \lambda(q_2) = 2$$

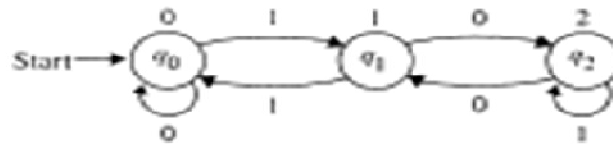

w=011 the output is 0010

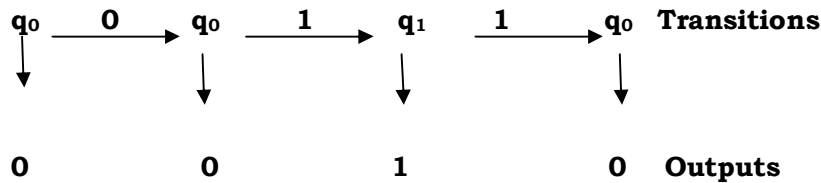

**Example:**

- The given transition diagram is mealy machine because output depends on present state and present input.
- In the below diagram

$$\begin{matrix} \lambda(q_0,0) = 0 & \lambda(q_1,0) = 2 & \lambda(q_2,0) = 0 \\ \lambda(q_0,1) = 1 & \lambda(q_1,1) = 0 & \lambda(q_2,1) = 2 \end{matrix}$$

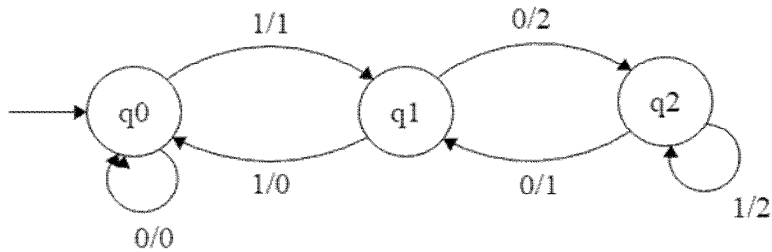

w=011 the output is 010

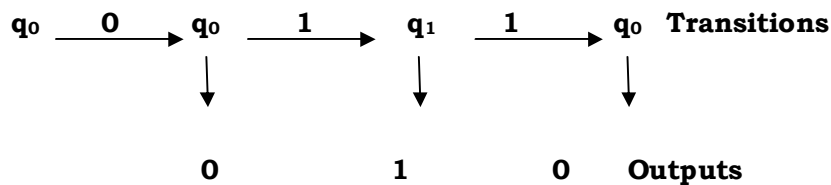

**Example:**

**1. Design Moore machine to determine the residue mod 3 for each binary string treated as a binary integer.**

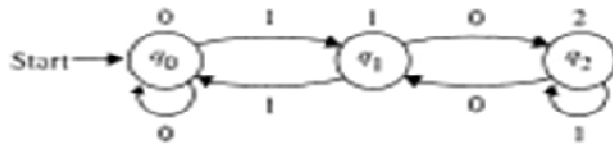

**Moore machine calculating residue mod 3**

**Moore Table**

| Present State    | Next State     |                | Output |
|------------------|----------------|----------------|--------|
|                  | 0              | 1              |        |
| → q <sub>0</sub> | q <sub>0</sub> | q <sub>1</sub> | 0      |
| q <sub>1</sub>   | q <sub>2</sub> | q <sub>0</sub> | 1      |
| q <sub>2</sub>   | q <sub>1</sub> | q <sub>2</sub> | 2      |

**Tuple Representation:**

$Q = \{q_0, q_1, q_2\}$

$\Delta = \{0, 1, 2\}$      $\Sigma = \{0, 1\}$

$q_0 = \{q_0\}$

$\lambda : \lambda(q_0) = 0$

$\delta : \delta(q_0, 0) = q_0$

$\delta(q_0, 1) = q_1$

$\lambda(q_1) = 1$

$\delta(q_1, 0) = q_2$

$\delta(q_1, 1) = q_0$

$\lambda(q_2) = 2$

$\delta(q_2, 0) = q_1$

$\delta(q_2, 1) = q_2$

**Example:**

1. Design Mealy machine to determine the residue mod 3 for each binary string treated as a binary integer.

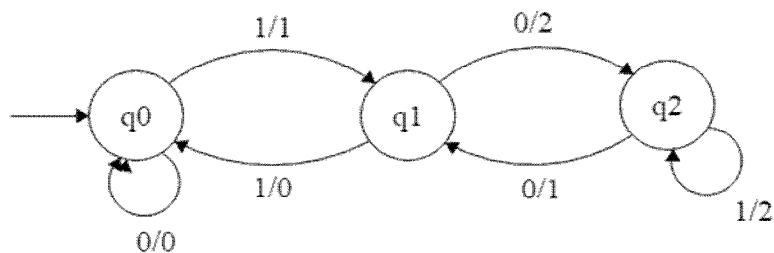



**Mealy Table:**

| Present State | Next State |        | Next State |        |
|---------------|------------|--------|------------|--------|
|               | 0          | Output | 1          | Output |
| $q_0$         | $q_0$      | 0      | $q_1$      | 1      |
| $q_1$         | $q_2$      | 2      | $q_0$      | 0      |
| $q_2$         | $q_1$      | 1      | $q_2$      | 2      |

**Tuple Representation:**

$$Q = \{q_0, q_1, q_2\} \quad \Delta = \{0, 1, 2\} \quad \Sigma = \{0, 1\}$$

$$q_0 = \{q_0\}$$

$$\lambda: \lambda(q_0, 0) = 0$$

$$\lambda(q_0, 1) = 1$$

$$\lambda(q_1, 0) = 2$$

$$\lambda(q_1, 1) = 0$$

$$\lambda(q_2, 0) = 1$$

$$\lambda(q_2, 1) = 2$$

$$\delta: \delta(q_0, 0) = q_0$$

$$\delta(q_1, 0) = q_2$$

$$\delta(q_2, 0) = q_1$$

$$\delta(q_0, 1) = q_1$$

$$\delta(q_1, 1) = q_0$$

$$\delta(q_2, 1) = q_2$$

**2.10 Moore to Mealy Conversion:**

If  $M_1 = (Q, \Sigma, \Delta, \delta, q_0, \lambda)$  is a Moore machine, then there is a Mealy machine  $M_2$  equivalent to  $M_1$ .

**Procedure:**

- Let  $M_2 = (Q, \Sigma, \Delta, \delta, q_0, \lambda')$  and define  $\lambda'(q, a)$  to be  $\lambda(\delta(q, a))$  for all states  $q$  and input symbols  $a$ .
- Then  $M_1$  and  $M_2$  enter the same sequence of states on the same input, and with each transition  $M_2$  emits the output that  $M_1$  associates with the state entered.

**Example:**

Construct a Mealy Machine which is equivalent to the Moore machine given by table below.

| Present State  | Next State     |                | Output |
|----------------|----------------|----------------|--------|
|                | 0              | 1              |        |
| q <sub>0</sub> | q <sub>3</sub> | q <sub>1</sub> | 0      |
| q <sub>1</sub> | q <sub>1</sub> | q <sub>2</sub> | 1      |
| q <sub>2</sub> | q <sub>2</sub> | q <sub>3</sub> | 0      |
| q <sub>3</sub> | q <sub>3</sub> | q <sub>0</sub> | 0      |

**Solution:**

$\lambda'(q, a)$  to be  $\lambda(\delta(q, a))$

$$\lambda'(q_0, 0) = \lambda(\delta(q_0, 0))$$

$$= \lambda(q_3)$$

$$= 0$$

$$\lambda'(q_1, 0) = \lambda(\delta(q_1, 0))$$

$$= \lambda(q_1)$$

$$= 1$$

$$\lambda'(q_2, 0) = \lambda(\delta(q_2, 0))$$

$$= \lambda(q_2)$$

$$= 0$$

$$\lambda'(q_3, 0) = \lambda(\delta(q_3, 0))$$

$$= \lambda(q_3)$$

$$= 0$$

$$\lambda'(q_0, 1) = \lambda(\delta(q_0, 1))$$

$$= \lambda(q_1)$$

$$= 1$$

$$\lambda'(q_1, 1) = \lambda(\delta(q_1, 1))$$

$$= \lambda(q_2)$$

$$= 0$$

$$\lambda'(q_2, 1) = \lambda(\delta(q_2, 1))$$

$$= \lambda(q_3)$$

$$= 0$$

$$\lambda'(q_3, 1) = \lambda(\delta(q_3, 1))$$

$$= \lambda(q_0)$$

$$= 0$$

**Mealy Table:**

| Present State  | Next State     |        | Next State     |        |
|----------------|----------------|--------|----------------|--------|
|                | 0              | output | 1              | Output |
| q <sub>0</sub> | q <sub>3</sub> | 0      | q <sub>1</sub> | 1      |
| q <sub>1</sub> | q <sub>1</sub> | 1      | q <sub>2</sub> | 0      |
| q <sub>2</sub> | q <sub>2</sub> | 0      | q <sub>3</sub> | 0      |
| q <sub>3</sub> | q <sub>3</sub> | 0      | q <sub>0</sub> | 0      |

### **2.11 Mealy to Moore Conversion:**

**If  $M_1 = (Q, \Sigma, \Delta, \delta, \lambda, q_0)$  is a Mealy machine, then there is a Moore machine  $M_2$  equivalent to  $M_1$ .**

***Procedure:***

- Determine the number of different output associated with  $q_i$  in the next state column.
- We split  $q_i$  into different states according to different output associated with it

For example:  $q_2$  is associated with two different outputs 0 and 1, so we split  $q_2$  into  $q_{20}$  and  $q_{21}$ .

***Example:***

**Construct Moore machine for the given mealy machine.**

| Present State | Next State |        |       |        |
|---------------|------------|--------|-------|--------|
|               | a = 0      |        | a = 1 |        |
|               | State      | Output | State | Output |
| -> q0         | q3         | 0      | q1    | 1      |
| q1            | q0         | 1      | q3    | 0      |
| q2            | q2         | 1      | q2    | 0      |
| q3            | q1         | 0      | q0    | 1      |

**Solution:**

- We get two states ( $q_1$  and  $q_2$ ) that are associated with different outputs (0 and 1). so we split both states into  $q_{10}$ ,  $q_{11}$  and  $q_{20}$ ,  $q_{21}$ .
- Whole row of  $q_1$  is copied to  $q_{10}$ ,  $q_{11}$  and whole row of  $q_2$  is copied to  $q_{20}$  and  $q_{21}$  of the sample transition table of mealy machine.
- The outputs of the next state columns of  $q_1$  and  $q_2$  are depend on the previous output. For ex. in the first row,  $q_1$  becomes  $q_{11}$  because the out of  $q_1$  is 1 in the fourth row,  $q_2$  becomes  $q_{21}$  because the output of the  $q_2$  is 1 and in the subsequent column  $q_2$  becomes  $q_{20}$  because the output of  $q_2$  in that column was 0. and so on

| Present State | Next State |       | Output |
|---------------|------------|-------|--------|
|               | a = 0      | a = 1 |        |
| -> q0         | q3         | q11   | 1      |
| q10           | q0         | q3    | 0      |
| q11           | q0         | q3    | 1      |
| q20           | q21        | q20   | 0      |
| q21           | q21        | q20   | 1      |
| q3            | q10        | q0    | 0      |

### **2.12 Applications of FA:**

- Used in Lexical analysis phase of a compiler to recognize tokens.
- Used in text editors for string matching.
- Software for designing and checking the behavior of digital circuits.

## UNIT - II

### Assignment-Cum-Tutorial Questions

#### SECTION-A

#### Objective Questions

1. What is the complement of the language accepted by the NFA shown below? [     ]

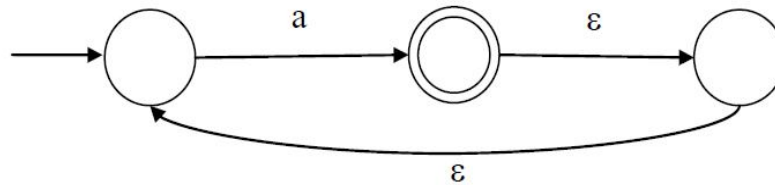

- (A)  $\emptyset$                       (B)  $\{\varepsilon\}$                       (C)  $a^*$                       (D)  $\{a, \varepsilon\}$
2. NFA with  $\varepsilon$  can increase the processing time of NFA **[True/False]**
3. \_\_\_\_\_ of a state is the set of states that can be reached by  $\varepsilon$ -transitions.
4. Let N be an NFA with n states and let M be the DFA with m states recognizing the same language. Which of the following is necessarily true? [     ]
- A)  $m \leq 2^n$               B)  $n \leq m$               (C) M has one accept state              D)  $m = 2^n$
5. Given a Non-deterministic Finite Automaton (NFA) with states p and r as initial states and final states respectively and transition table as given below:

|   |   |   |
|---|---|---|
|   | a | b |
| p | - | q |
| q | r | s |
| r | r | s |
| s | r | s |

- The minimum number of states required in Deterministic Finite Automaton (DFA) equivalent to NFA is [     ]
- (A) 5                      (B) 4                      (C) 3                      (D) 2
6. The output in \_\_\_\_\_ machine is associated with transition. [     ]
- (A) Moore                      (B) Mealy                      (C) both                      (D) DFA
7. The two states  $q_1$  and  $q_2$  are said to be \_\_\_\_\_ if both  $\delta(q_1, a)$  and  $\delta(q_2, a)$  reach final states or both of them reach non final states for all  $a \in \Sigma$ .

8. For a Moore machine if the input string is of length  $n$ , the output string is of length  $n + 1$ . **[True/False]**
9. In a Mealy machine if the input string is of length  $n$ , the output string is of length \_\_\_\_\_.  
 (A)  $n$  (B)  $n+1$  (C)  $2n$  (D)  $n+2$
10. Choose incorrect statement. [ ]  
 (A) Moore and Mealy machines are FSM's with output capability.  
 (B) Any given Moore machine has an equivalent Mealy Machine.  
 (C) Any given Mealy machine has an equivalent Moore Machine.  
 (D) Moore Machine is not a FSM.
11. Which of the following statement is true? [ ]  
 (A) A Mealy machine has no terminating state  
 (B) A Moore machine has no terminating state  
 (C) Converting from Mealy into Moore machine and vice versa is possible  
 (D) All of these
12. The output alphabet in Moore machine can be represented formally as  
 (A)  $\Delta$  (B)  $\Sigma$  (C)  $\delta$  (D)  $\lambda$  [ ]
13. Consider the table

| Present State | Next State |        |       |        |
|---------------|------------|--------|-------|--------|
|               | 0          |        | 1     |        |
|               | state      | output | state | output |
| $q_0$         | $q_0$      | 0      | $q_1$ | 1      |
| $q_1$         | $q_2$      | 2      | $q_0$ | 0      |
| $q_2$         | $q_1$      | 1      | $q_2$ | 2      |

If the initial state is  $q_0$ . What is the output sequence for the string 101?

- (A) 0012 (B) 122 (C) 112 (D) 0122 [ ]

### SECTION-B

#### Descriptive Questions

1. Construct DFA equivalent to the NFA given below

$M = (\{q_0, q_1, q_2, q_3\}, \{a, b\}, \delta, q_0, \{q_3\})$  where  $\delta$  is given as

|      |         |    |
|------|---------|----|
|      | a       | b  |
| → q0 | {q0,q1} | q0 |
| q1   | q2      | q1 |
| q2   | q3      | q3 |
| ⊙ q3 | -       | q2 |

2. Construct an equivalent DFA for a N DFA  $M = (\{q_1, q_2, q_3\}, q_1, q_3)$  where  $\delta$  is given by:

$$\begin{aligned} \delta(q_1, 0) &= \{q_2, q_3\}, & \delta(q_1, 1) &= \{q_1\}, \\ \delta(q_2, 0) &= \{q_1, q_2\}, & \delta(q_2, 1) &= \emptyset \\ \delta(q_3, 0) &= \{q_2\}, & \delta(q_3, 1) &= \{q_1, q_2\} \end{aligned}$$

3. Define  $\epsilon$ -closure. Find the  $\epsilon$ -closures of the each state in the following  $\epsilon$ -NFA.

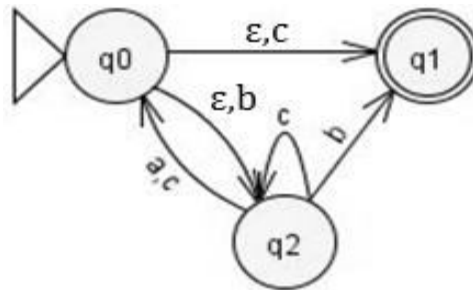

4. Consider the following finite automaton with epsilon moves obtain equivalent automaton without epsilon moves.

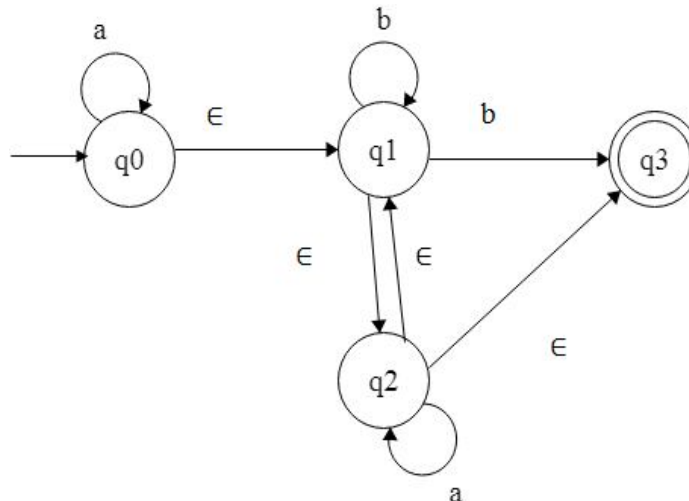

5. Construct a NFA without  $\epsilon$  for the following NFA with  $\epsilon$ .

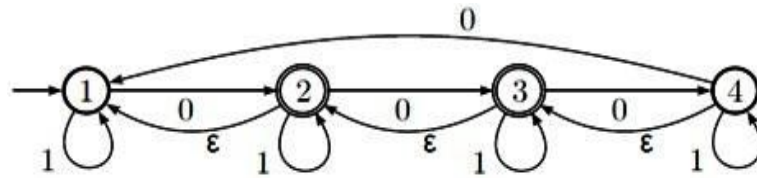

6. Verify whether the following FA is equivalent?

|     |   |   |
|-----|---|---|
|     | 0 | 1 |
| → A | B | D |
| (B) | A | C |
| C   | D | B |
| (D) | C | A |

|     |   |   |
|-----|---|---|
|     | 0 | 1 |
| → P | R | R |
| Q   | R | P |
| (R) | P | Q |

7. Find the equivalence between M1 & M2

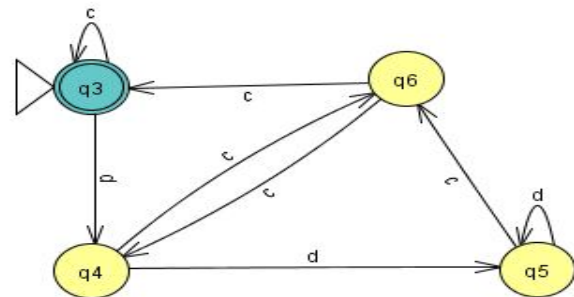
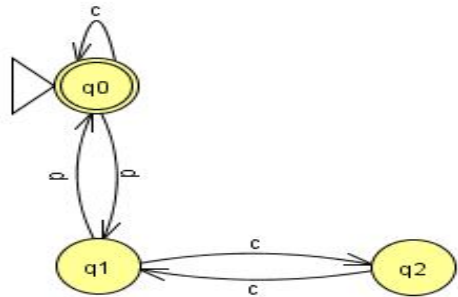

8. Construct the minimum state automaton equivalent to the transition diagram

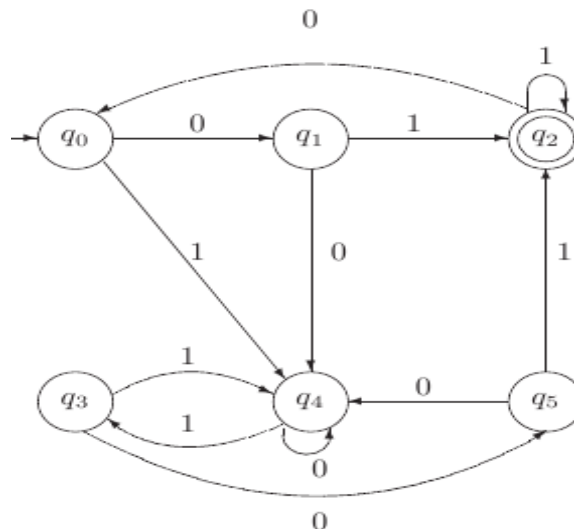

9. Construct a minimum state automaton equivalent to a given automaton  $M$  whose transition table is defined by table



|     |   |   |
|-----|---|---|
|     | 0 | 1 |
| → A | B | D |
| B   | C | E |
| C   | B | E |
| D   | C | E |
| ⊙ E | E | E |

10. Design a Moore machine to determine the residue mod 4 for each binary string treated as integers.
11. Construct a Mealy machine which can output EVEN or ODD according as the total number of 1's encountered is even or odd. The input symbols are 0 and 1.
12. Design a Mealy machine to find out 2's complement of a binary number.
13. Design Moore and Mealy machines to find out 1's complement of a binary number.
14. Construct a Moore machine that takes set of all strings over {a,b} as input and prints '1' as output for every occurrence of 'ab' as a substring.
15. Design a Mealy machine that uses its states to remember the last symbol read and emits output 'y' whenever current input matches to previous one, and emits n otherwise
16. Give Mealy and Moore machines for the following process: For input from  $(0+1)^*$ , if the input ends in 101, output A; If the input ends in 110 output B; otherwise output C.
17. Convert the following Mealy machine to Moore machine

| Present State | Next State |        |       |        |
|---------------|------------|--------|-------|--------|
|               | a = 0      |        | a = 1 |        |
|               | State      | Output | State | Output |
| -> q0         | q3         | 0      | q1    | 1      |
| q1            | q0         | 1      | q3    | 0      |
| q2            | q2         | 1      | q2    | 0      |
| q3            | q1         | 0      | q0    | 1      |

18. Construct a Mealy machine which is equivalent to the Moore machine given in table:

| Present State    | Next State     |                | Output |
|------------------|----------------|----------------|--------|
|                  | A=0            | A=1            |        |
| → q <sub>0</sub> | q <sub>3</sub> | q <sub>1</sub> | 0      |
| q <sub>1</sub>   | q <sub>1</sub> | q <sub>2</sub> | 1      |
| q <sub>2</sub>   | q <sub>2</sub> | q <sub>3</sub> | 0      |
| q <sub>3</sub>   | q <sub>3</sub> | q <sub>0</sub> | 0      |

19. Convert the following Mealy machine into its equivalent Moore machine

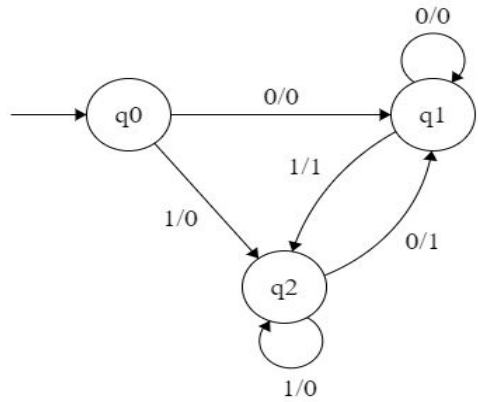

**SECTION-C**

**Gate Questions:**

1. Let  $\delta$  denote the transition function and  $\hat{\delta}$  denote the extended transition function of the  $\epsilon$ -NFA whose transition table is given below:

[GATE 2017 (Set 2)]

| $\delta$         | $\epsilon$        | $a$               | $b$               |
|------------------|-------------------|-------------------|-------------------|
| → q <sub>0</sub> | {q <sub>2</sub> } | {q <sub>1</sub> } | {q <sub>0</sub> } |
| q <sub>1</sub>   | {q <sub>2</sub> } | {q <sub>2</sub> } | {q <sub>3</sub> } |
| q <sub>2</sub>   | {q <sub>0</sub> } | $\emptyset$       | $\emptyset$       |
| q <sub>3</sub>   | $\emptyset$       | $\emptyset$       | {q <sub>2</sub> } |

Then  $\hat{\delta}(q_2, aba)$  is [ ]

- A)  $\emptyset$       B) {q<sub>0</sub>,q<sub>1</sub>,q<sub>3</sub>}      C) {q<sub>0</sub>,q<sub>1</sub>,q<sub>2</sub>}      D) {q<sub>0</sub>,q<sub>2</sub>,q<sub>3</sub>}

2. A deterministic finite automation (DFA)D with alphabet  $\Sigma=\{a,b\}$  is given below

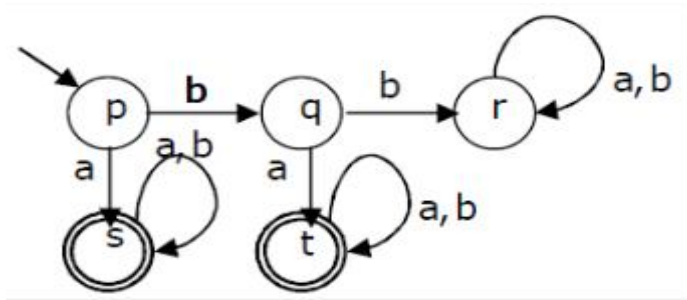

[GATE 2011]

Which of the following finite state machines is a valid minimal DFA which accepts the same language as D? [ ]

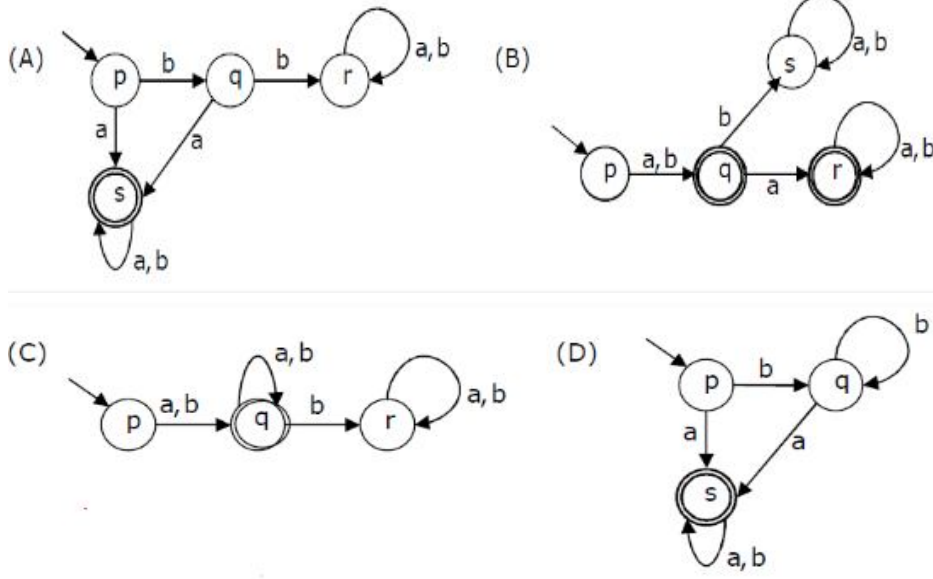

3. Consider the following finite state automaton [ ]

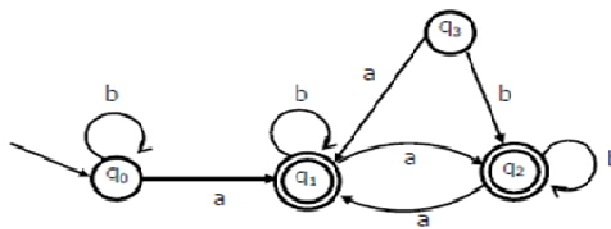

The minimum state automaton equivalent to the above FSA has the following number of states [GATE 2007] [ ]

- A) 1                      B) 2                      C) 3                      D) 4

4. The following diagram represents a finite state machine which takes as input a binary number from the least significant bit. [GATE 2005]

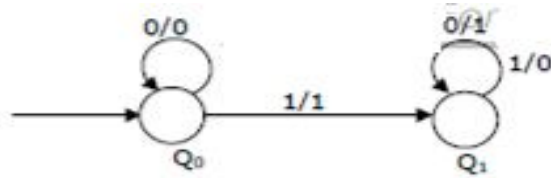

Which one of the following is true? [      ]

- A) It computes 1's complement of the input number
  - B) It computes 2's complement of the input number
  - C) It increments the input number
  - D) It decrements the input number
5. The finite state machine described by the following state diagram with A as starting state, where an arc label is x/y and x stands for 1-bit input and y stands for 2-bit output [GATE 2002] [      ]

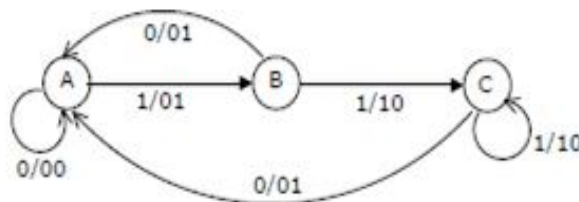

- A) Outputs the sum of the present and the previous bits of the input
- B) Outputs 01 whenever the input sequence contains 11
- C) Outputs 00 whenever the input sequence contains 10
- D) None of the above

### UNIT-III

**Objective:**

To familiarize how to employ regular expressions.

**Syllabus:**

Regular sets, regular expressions, identity rules, construction of finite Automata for a given regular expressions and its inter conversion, pumping lemma of regular sets, closure properties of regular sets (proofs not required), applications of regular languages.

**Learning Outcomes:**

Students will be able to:

- understand the regular sets and how to represent the regular expressions.
- construct finite Automata for a given regular expression and viceversa.
- list closure properties of regular languages.
- understand the different applications of regular languages.

### 3.Learning Material

**3.1 Regular set:**

A language is a regular set (or just regular) if it is the set accepted by some finite automaton.

***Example:***

$L = \{0, 1, 10, 00, 01, 11, 000, 101, \dots\}$  is a regular set representing any no of 0's and any no of 1's.

**3.2 Regular expression:**

The languages accepted by finite automata are easily described by simple expressions called regular expressions.

Let  $\Sigma$  be an alphabet. The regular expressions over  $\Sigma$  and the sets that they denote are defined recursively as follows.

- 1)  $\emptyset$  is a regular expression and denotes the empty set.
- 2)  $\epsilon$  is a regular expression and denotes the set  $\{\epsilon\}$ .
- 3) For each  $a$  in  $\Sigma$ ,  $a$  is a regular expression and denotes the set  $\{a\}$ .

4) If  $r$  and  $s$  are regular expressions denoting the languages  $R$  and  $S$ , respectively, then

$(r + s)$ ,  $(rs)$ , and  $(r^*)$  are regular expressions that denote the sets  $R \cup S$ ,  $RS$ , and  $R^*$ , respectively.

### **3.2.1 Some Examples on Regular expressions**

**1. Write regular expressions for each of the following languages over  $\Sigma = \{0, 1\}$ .**

a) The set representing  $\{00\}$ .

**$00$**

b) The set representing all strings of 0's and 1's.

**$(0+1)^*$**

c) The set of all strings representing with at least two consecutive 0's.

**$(0 + 1)^*00(0 + 1)^*$**

d) The set of all strings ending in 011.

**$(0 + 1)^*011$**

e) The set of all strings representing any number of 0's followed by any number of 1's followed by any number of 2's.

**$0^*1^*2^*$**

f) The set of all strings starting with 011.

**$011(0 + 1)^*$**

**2. Write regular expressions for each of the following languages over  $\Sigma = \{a, b\}$ .**

a) The set of all strings ending with either  $a$  or  $bb$ .

**$(a+b)^*(a + bb)$**

b) The set of strings consisting of even no. of  $a$ 's followed by odd no. of  $b$ 's.

**$(aa)^*(bb)^*b$**

c) The set of strings representing even number of  $a$ 's.

**$(b^* a b^* a b^*)^* + b^*$**

### 3.3 Identity Rules Related to Regular Expressions

Given  $r$ ,  $s$  and  $t$  are regular expressions, the following identities hold:

- $\emptyset^* = \varepsilon$
- $\varepsilon^* = \varepsilon$
- $r^+ = rr^* = r^*r$
- $r^*r^* = r^*$
- $(r^*)^* = r^*$
- $r + s = s + r$
- $(r + s) + t = r + (s + t)$
- $(rs)t = r(st)$
- $r(s + t) = rs + rt$
- $(r + s)t = rt + st$
- $(\varepsilon + r)^* = r^*$
- $(r + s)^* = (r^*s^*)^* = (r^* + s^*)^* = (r+s^*)^*$
- $r + \emptyset = \emptyset + r = r$
- $r\varepsilon = \varepsilon r = r$
- $\emptyset L = L\emptyset = \emptyset$
- $r + r = r$
- $\varepsilon + rr^* = \varepsilon + r^*r = r^*$

### 3.4 Construction of Finite automata for a given regular expression

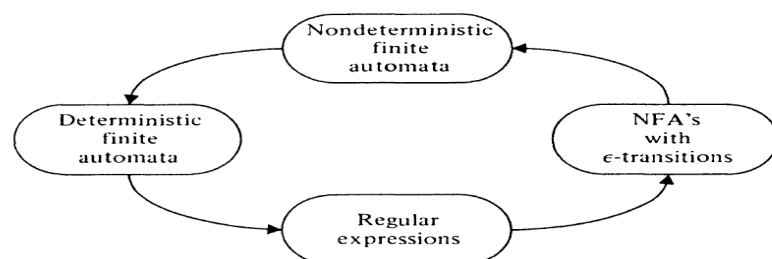

### **Equivalence of Finite Automata and Regular Expressions**

- The languages accepted by finite automata are precisely the languages denoted by regular expressions.
- For every regular expression there is an equivalent NFA with  $\epsilon$  - transitions.
- For every DFA there is a regular expression denoting its language.

**Let  $r$  be a regular expression. Then there exists an NFA with  $\epsilon$  -transitions that accept  $L(r)$ .**

#### **Zero operators:**

The expression  $r$  must be  $\epsilon$ ,  $\emptyset$ , or  $a$  for some  $a$  in  $\Sigma$ . The NFA's for zero operators are

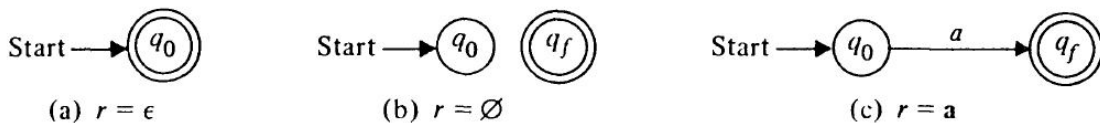

#### **One or more operators:**

Let  $r$  have  $i$  operators. There are three cases depending on the form of  $r$ .

##### **Case 1: Union ( $r = r_1 + r_2$ .)**

There are NFA's  $M_1 = (Q_1, \Sigma_1, \delta_1, q_1, \{f_1\})$  and  $M_2 = (Q_2, \Sigma_2, \delta_2, q_2, \{f_2\})$  with  $L(M_1) = L(r_1)$  and  $L(M_2) = L(r_2)$ .

Construct

$M = (Q_1 \cup Q_2 \cup \{q_0, f_0\}, \Sigma_1 \cup \Sigma_2, \delta, q_0, \{f_0\})$  where  $\delta$  is defined by

**i)  $\delta(q_0, \epsilon) = \{q_1, q_2\}$**

**ii)  $\delta(q, a) = \delta_1(q, a)$  for  $q$  in  $Q_1 - \{f_1\}$  and  $a$  in  $\Sigma_1 \cup \{\epsilon\}$**

**iii)  $\delta(q, a) = \delta_2(q, a)$  for  $q$  in  $Q_2 - \{f_2\}$  and  $a$  in  $\Sigma_2 \cup \{\epsilon\}$**

**iv)  $\delta(f_1, \epsilon) = \delta_1(f_2, \epsilon) = \{f_0\}$**



**$L(M) = L(M1) \cup L(M2)$**

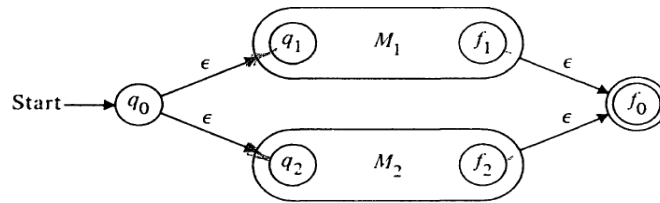

**Case 2: Concatenation ( $r = r1 r2$ ).**

Let M1 and M2 be as in Case 1 and construct  $M = (Q1 \cup Q2, \Sigma1 \cup \Sigma2, \delta, q1, \{f2\})$

where  $\delta$  is defined by

i)  $\delta(q, a) = \delta1(q, a)$  for  $q$  in  $Q1 - \{f1\}$  and  $a$  in  $\Sigma1 \cup \{\epsilon\}$

ii)  $\delta(f1, \epsilon) = \{q2\}$

iii)  $\delta(q, a) = \delta2(q, a)$  for  $q$  in  $Q2$  and  $a$  in  $\Sigma2 \cup \{\epsilon\}$

$L(M) = \{xy \mid x \text{ is in } L(M1) \text{ and } y \text{ is in } L(M2)\}$  and  $L(M) = L(M1)L(M2)$

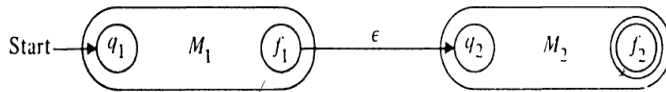

**Case 3: Closure ( $r = r1^*$ )**

Let  $M1 = (Q1, \Sigma1, \delta1, q1, \{f1\})$  and  $L(M1) = r1$ .

**Construct  $M = (Q1 \cup \{q0, f0\}, \Sigma1, \delta, q0, \{f0\})$ , where  $\delta$  is defined by**

i)  $\delta(q0, \epsilon) = \delta(f1, \epsilon) = \{q1, f0\}$

ii)  $\delta(q, a) = \delta1(q, a)$  for  $q$  in  $Q1 - \{f1\}$  and  $a$  in  $\Sigma1 \cup \{\epsilon\}$

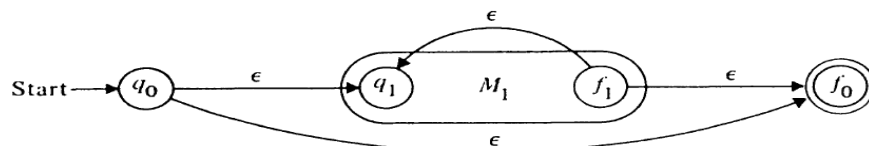

**Example:****1. Construct an NFA for the regular expression  $01^*1$** 

Regular expression is of the form  $r_1 + r_2$ , where  $r_1 = 01^*$  and  $r_2 = 1$ .

The automaton for  $r_2$  is

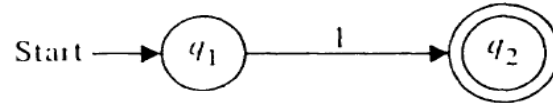

Express  $r_1$  as  $r_3$  and  $r_4$ , where  $r_3=0$  and  $r_4= 1^*$

The automaton for  $r_3$  is

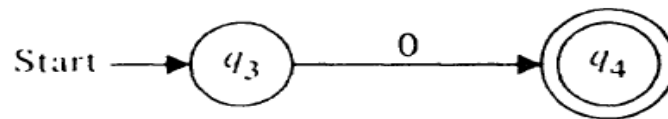

$r_4$  is  $r_5^*$  where  $r_5=1$

The NFA for  $r_5$  is

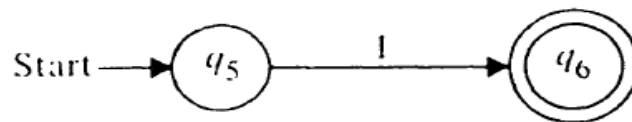

To construct an NFA for  $r_4 = r_5^*$  use the construction of closure. The resulting NFA for  $r_4$  is

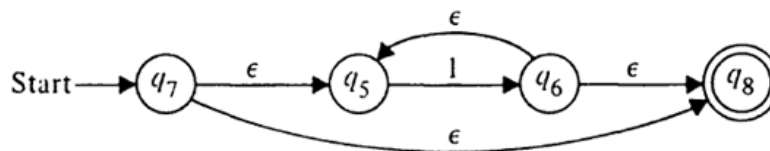

Then, for  $r_1 = r_3 r_4$  use the construction of concatenation.

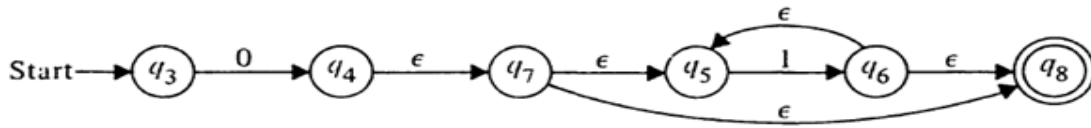

Finally, use the construction of union to find the NFA for  $r = r_1 + r_2$

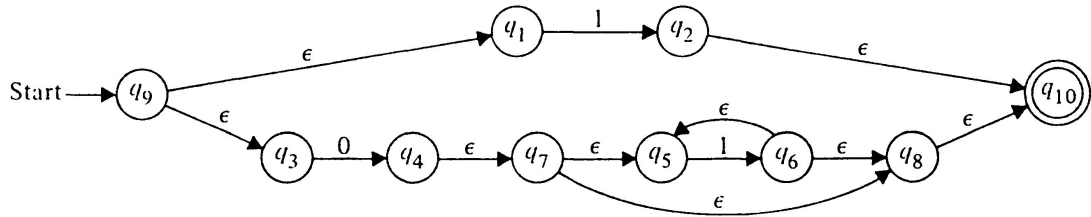

**3.5 Construction of regular expressions for the given finite Automata:**

**Arden's Theorem**

Let P and Q be two regular expressions over  $\Sigma$ , and if P does not contain epsilon, then  $R=Q+RP$  has a unique solution  $R=QP^*$ .

**Procedure:**

Assume the given finite automata should not contain any epsilons.

**Step 1:** Find the reachability for each and every state in given Finite automata.

**Reachability** of a state is the set of states whose edges enter into that state.

**Step 2:** For the initial state of finite automata ,add epsilon to the reachability equation.

**Step 3:** Solve the equations by using Arden's Theorem.

**Step 4:** Substitute the results of each state equation into the final state equation, to get the regular expression for the given DFA.

**Example:**

**1. Construct regular expression for the given finite automaton.**

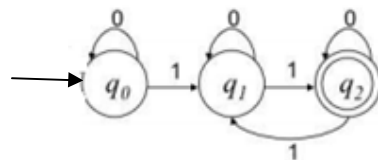

The given Finite Automata is not having any  $\epsilon$ 's( epsilons).

**Step 1:** Find the reachability for each and every state in given Finite automata.

**Reachability** of a state is the set of states whose edges enter into that state.

$$q_0 = q_0 0 \quad \text{—————} \quad 1$$

$$q_1 = q_0 1 + q_1 0 + q_2 1 \quad \text{—————} \quad 2$$

$$q_2 = q_1 1 + q_2 0 \quad \text{—————} \quad 3$$

**Step 2:** For the initial state of finite automata, add epsilon to the reachability equation.

$$q_0 = q_0 0 + \epsilon$$

**Step 3:** Solve the equations by using Arden's Theorem.

After applying arden's theorem for equation 3

$$q_2 = q_1 10^* \quad \text{—————} \quad 4$$

Substitute equation 4 in equation 2

$$q_1 = q_0 1 + q_1 0 + q_1 10^*$$

$$q_1 = q_0 1 + q_1(0+10^*) \quad \text{—————} \quad 5$$

Apply arden's theorem on equation 5

$$q_1 = q_0 1 (0+10^*)^* \quad \text{—————} \quad 6$$

Apply arden's theorem on equation 1

$$q_0 = q_0 0 + \epsilon$$

$$q_0 = \epsilon 0^* \quad \text{—————} \quad 7$$

Substitute equation 7 in equation 6

$$q_1 = \epsilon 0^* 1 (0+10^*)^* \quad \text{—————} \quad 8$$

**Step 4:** Substitute the results of each state equation into the final state equation, to get the regular expression for the given DFA.

$$q_2 = \epsilon 0^* 1 (0+10^*)^* 10^*$$

Therefore, the regular expression for the given DFA is  $0^* 1 (0+10^*)^* 10^*$ .

### 3.6 Pumping Lemma for Regular Sets:

- Pumping lemma, which is a powerful tool for proving certain languages non-regular.

- It is also useful in the development of algorithms to answer certain questions concerning finite automata, such as whether the language accepted by a given FA is finite or infinite.

### Lemma

Let  $L$  be a regular set. Then there is a constant  $n$  such that if  $z$  is any word in  $L$ , and  $|z| > n$ , we may write  $z=uvw$  in such a way that  $|uv| \leq n$ ,  $v \geq 1$ , and for all  $i > 0$ ,  $uv^i w$  is in  $L$ . Furthermore,  $n$  is no greater than the number of states of the smallest FA accepting  $L$ .

### ***Example:***

**The set  $L = \{0^{i^2} \mid i \text{ is an integer, } i \geq 1\}$ , which consists of all strings of 0's whose length is a perfect square, is not regular.**

Assume  $L$  is regular and let  $n$  be the integer in the pumping lemma.

Let  $z = 0^{n^2}$ .

By the pumping lemma,  $0^{n^2}$  may be written as  $uvw$ , where  $1 \leq |v| \leq n$  and  $uv^i w$  is in  $L$  for all  $i$ . Let  $i = 2$ ,  $n^2 < |uv^2 w| < n^2 + n < (n+1)^2$ .

That is, the length of  $uv^2 w$  lies properly between  $n^2$  and  $(n+1)^2$ , and is thus not a perfect square.

Thus  $uv^2 w$  is not in  $L$ , a contradiction.

We conclude that  $L$  is not regular.

### **3.7 Closure Properties of Regular Sets:**

- The regular sets are closed under union, concatenation, and Kleene closure.
- The class of regular sets is closed under complementation. That is, if  $L$  is a regular set and  $L \subseteq \Sigma^*$ , then  $\Sigma^* - L$  is a regular set.
- The regular sets are closed under intersection.
- The class of regular sets is closed under substitution.
- The class of regular sets is closed under homomorphism and inverse homomorphism.
- The class of regular sets is closed under quotient with arbitrary sets.

### **3.8 Applications of Regular Languages:-**

- Efficient string searching .
- Pattern matching with regular expressions (example: Unix grep utility)
- Lexical analysis (a.k.a. scanning, tokenizing) in a compiler.

**UNIT - III****Assignment-Cum-Tutorial Questions  
SECTION-A****Objective Questions**

- The languages accepted by finite automata are easily described by simple expressions called\_\_\_\_\_.
- A language is a \_\_\_\_\_ if it is the set accepted by some finite automaton.
- What is the solution for equation  $R=Q+RP$  (if  $P$  and  $Q$  are RE and  $P$  does not contain  $\epsilon$ )?  
 (a)  $R=QP^*$                       (b)  $R=QP$                       (c)  $R=PQ^*$                       (d)  $R=P^*Q^*$                       [       ]
- $\emptyset + R =$ \_\_\_\_\_.
- $\emptyset^* =$ \_\_\_\_\_.
- $\epsilon^* =$ \_\_\_\_\_.
- $\epsilon + r r^* = r^*$     [ True / False]
- Pumping lemma is generally used for proving \_\_\_\_\_ [       ]  
 A) a given grammar is regular  
 B) a given grammar is not regular  
 C) whether two given regular expressions are equivalent  
 D) none of the above
- Regular sets are closed under \_\_\_\_\_ [       ]  
 A) Union    B) concatenation  
 C) Kleene closure                                      D) All of the above
- $a + b$  denotes the set \_\_\_\_\_ [       ]  
 A)  $\{a, b\}$                       B)  $\{ab\}$                       C)  $\{a\}$                       D)  $\{b\}$
- The set of all strings of  $\{0, 1\}$  having exactly two 0's is \_\_\_\_\_ [       ]  
 A)  $1^*01^*01^*$                       B)  $\{(0+1)^*\}$                       C)  $\{11+0\}^*$                       D)  $\{00+11\}^*$
- The regular expression to represent all strings with length atmost 2 over  $\{a,b\}$  is\_\_\_\_\_ [       ]  
 A)  $\epsilon$                       B)  $\epsilon+(a+b)+(a+b).(a+b)$                       C)  $(a+b)$                       D)  $(a+b).(a+b)$
- Which one of the following languages over the alphabet  $\{0, 1\}$  is described by the regular expression:  $(0+1)^*0(0+1)^*0(0+1)^*$ ? [       ]  
 A) The set of all strings containing the substring 00.  
 B) The set of all strings containing atmost two 0's.  
 C) The set of all strings containing atleast two 0's.  
 D) The set of all strings that begin and end with either 0 or 1.

14. Consider the languages  $L1 = \epsilon$  and  $L2 = \{0\}$ . Which one of the following represents  $L1 L2^* + L1^*$  [     ]

- A)  $\{\epsilon\}$                       B)  $\emptyset$                       C)  $0^*$                       D)  $\{\epsilon, 0\}$

15. What is the regular expression for the given DFA? [     ]

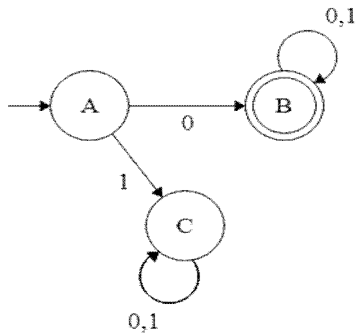

- (a)  $(0+1)^*$                       (b)  $0(0+1)^*$                       (c)  $0$                       (d)  $(0+1)^*0$

16. Which of the following languages are not regular? [     ]

- (a)  $L = \{a^n \mid n \geq 1\}$  (b)  $L = \{a^n b^m \mid n, m \geq 1\}$                       (c)  $a^n b^n \mid n \geq 1$                       (d)  $a^{2n} \mid n \geq 0$

17. What is the regular expression for the given DFA? [     ]

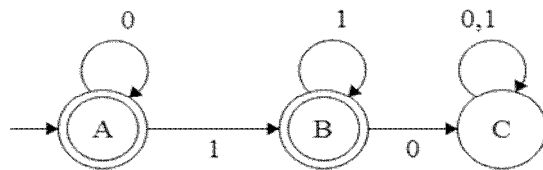

- (a)  $0^*1^+$                       (b)  $0^*1^*$                       (c)  $1^*0^*$                       (d)  $1^*0^+$

**SECTION-B**

**Descriptive questions**

1. Define regular set and regular expression.
2. State Arden's Theorem.
3. List the closure properties of Regular Languages.
4. Explain in detail the procedure for converting Finite automata into regular expression with an example.
5. Write regular expressions for each of the following languages over  $\Sigma = \{0, 1\}$ 
  - (i) The set of all strings representing with at least two consecutive 0's
  - (ii) The set of all strings ending in 011
  - (iii) The set of all strings starting with 101
  - (iv) The set of all strings containing 011 as substring



- (v) The set of all strings that start and end with same symbol
- 6. Design a  $\epsilon$ -NFA for the regular expression  $a^*bc \mid ab^* \mid c^*$ .
- 7. Construct NFA with  $\epsilon$ -moves for the regular expression  $10+(0+11)0^*1$
- 8. Construct Finite automata for the regular expression  $1(01+10)^*00$ .
- 9. Construct finite automation to accept the regular expression  $(0+1)^* (00+11)(0+1)^*$ .
- 10. Define Pumping Lemma. Apply pumping lemma and show that the language  $L = \{ a^n b^{2n} \mid n > 0 \}$  is not regular.
- 11. What are the applications of pumping lemma? Show that the language  $L = \{ a^n b^n c^n \mid n \geq 1 \}$  is not regular.
- 12. Using pumping lemma, show the following language is not regular:  
 $L = \{ w \in \{0,1\}^* \mid \text{the number of 0's in } w \text{ is a perfect square} \}$
- 13. Applying Arden's Theorem construct regular expression for the DFA given below

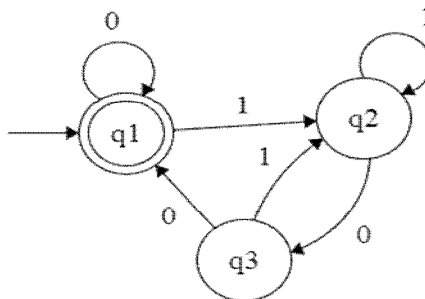

- 14. Construct regular expression for the following DFA.

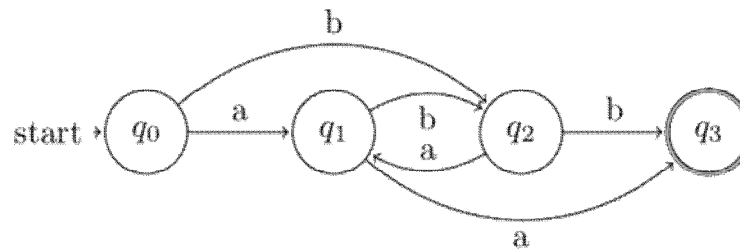

- 15. What is the regular expression for the given DFA?

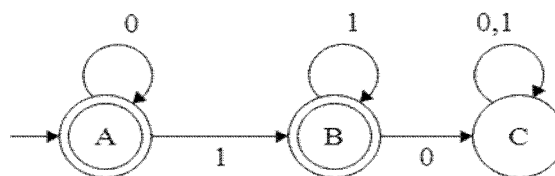

**SECTION-C**

**Gate Questions:**

1. The number of states in the minimum sized DFA that accepts the language defined by the regular expression  $(0+1)^*(0+1)(0+1)^*$  is\_\_\_\_\_.

[GATE 2016 Set-B]

2. Which of the regular expressions given below represent the following DFA?

[ ] [GATE 2014 Set-1]

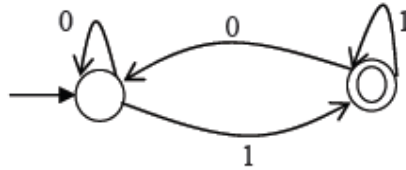

- I)  $0^*1(1+00^*1)^*$
- II)  $0^*1^*1+11^*0^*1$
- III)  $(0+1)^*1$

- A) I and II only
- B) I and III only
- C) II and III only
- D) I, II and III only

3. Consider the languages  $L1 = \emptyset$  and  $L2 = \{a\}$ . Which one of the following represents  $L1 L2^* \cup L1^*$  [ ] [GATE 2013]

- A)  $\{\square\}$
- B)  $\emptyset$
- C)  $a^*$
- D)  $\{\square, a\}$

4. Let  $L = \{w \in (0 + 1)^* | w \text{ has even number of 1s}\}$ , i.e. L is the set of all bit strings with even number of 1s. Which one of the regular expressions below represents L? [ ] [GATE 2010]

- A)  $(0^*10^*1)^*$
- B)  $0^*(10^*10^*)^*$
- C)  $0^*(10^*1^*)^*0^*$
- D)  $0^*1(10^*1)^*10^*$

5. The language accepted by this automaton is given by the regular expression [ ] [GATE 2007]

- A)  $b^*ab^*ab^*ab^*$
- B)  $(a+b)^*$
- C)  $b^*a(a+b)^*$
- D)  $b^*ab^*ab^*$

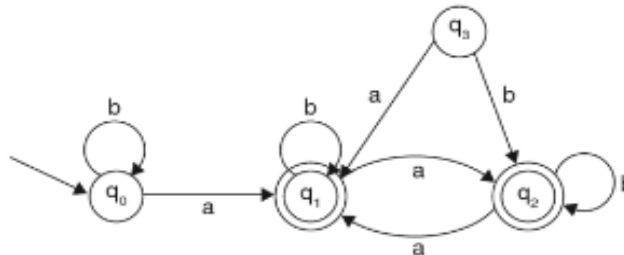

6. Consider the language  $L=(111+11111)^*$ .The minimum number of states in any DFA accepting this language is: [ ] [GATE 2006]

A)3                      B) 5                      C) 8                      D) 9

7. The number of states in the minimal deterministic finite automaton corresponding to the regular expression  $(0 + 1)^*(10)$  is **[GATE 2010]**

A) 2                      B) 3                      C) 4                      D) 5

## UNIT-IV

**Objective:**

To understand regular grammars and context free grammars.

**Syllabus:**

Chomsky hierarchy of languages, Regular grammars- right linear and left linear grammars, Equivalence between regular linear grammar and FA and its inter conversion, Context free grammar, derivation trees, Sentential forms, right most and left most derivation of strings

**Learning Outcomes:**

Students will be able to:

- understand Chomsky hierarchy of languages.
- understand and construct the regular grammar for the given regular language or regular expression.
- convert Regular Grammar into equivalent DFA and viceversa.
- construct Context free grammar for the given language.
- construct right most, left most derivation and derivation trees for the given string and grammar.

## Learning Material

### 4.1 Chomsky hierarchy of languages:

The four classes of languages are often called the Chomsky hierarchy, after Noam Chomsky, who defined these classes as potential models of natural languages.

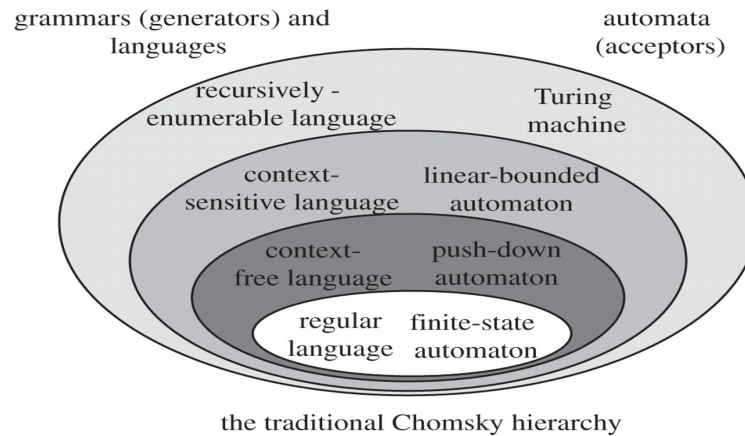

Fig:4.1 **Chomsky hierarchy**

Chomsky classifies the grammar into four types:

Table:4.1Types of Grammar

| <b>Grammar</b> | <b>Languages</b>                             | <b>Automaton</b>      | <b>Production rules</b>                               |
|----------------|--|-----------------------|---|
| Type 0         | Recursively enumerable/<br>Phrase Structured | Turing machines       | $\alpha \rightarrow \beta$                            |
| Type 1         | Context-sensitive                            | Linear-bound automata | $\alpha \rightarrow \beta$<br>$ \alpha  \leq  \beta $ |
| Type 2         | Context-free                                 | Push-down automata    | $A \rightarrow \alpha$                                |

|        |         |                       |   |
|--------|---------|-----------------------|---|
| Type 3 | Regular | Finite-state automata | $A \rightarrow w$<br>$A \rightarrow wB$<br>$A \rightarrow Bw$ |
|--------|---------|-----------------------|---|

#### **4.1.1 Regular Grammar:**

A right- or left-linear grammar is called a regular grammar.

#### **Right-Linear Grammar:**

If all productions of a grammar are of the form  $A \rightarrow wB$  or  $A \rightarrow w$ , where  $A$  and  $B$  are variables and  $w$  is a (possibly empty) string of terminals, then we say the grammar is right-linear.

#### ***Example:***

**Represent the language  $0(10)^*$  by the right-linear grammar.**

The language generated by the given Regular Expression is

$$L = \{0, 010, 01010, 0101010, \dots\}$$

*Right-Linear Grammar:*

$$S \rightarrow 0A$$

$$A \rightarrow 10A \mid \epsilon$$

#### **Left-Linear Grammar:**

If all productions are of the form  $A \rightarrow Bw$  or  $A \rightarrow w$ , we call it left-linear.

#### ***Example:***

**Represent the language  $0(10)^*$  by the left-linear grammar.**

The language generated by the given Regular Expression is

$$L = \{0, 010, 01010, 0101010, \dots\}$$

*Left-Linear Grammar:*

$$S \rightarrow S10 \mid 0$$

**Equivalence of regular grammars and finite automata:**

A language is regular if and only if it has a left-linear grammar and if and only if it has a right-linear grammar.

**Construction of a Regular Grammar for a given DFA:**

Let  $M = (\{q_0, q_1 \dots q_n\}, \Sigma, \delta, q_0, F)$ . We construct  $G$  as  $G = (\{A_0, A_1, \dots, A_n\}, \Sigma, P, A_0)$

where  $P$  is defined by the following rules:

(i)  $A_i \rightarrow aA_j$  is included in  $P$  if  $\delta(q_i, a) = q_j \notin F$ .

(ii)  $A_i \rightarrow aA_j$  and  $A_i \rightarrow a$  are included in  $P$  if  $\delta(q_i, a) = q_j \in F$ .

**Note:** We can construct only right linear grammar for the given DFA.

If we want to construct **left linear grammar** for the given DFA, reverse the edges of the given DFA and interchange initial and final states.

**Example:**

- Construct regular grammar (right linear grammar) for the given DFA.**

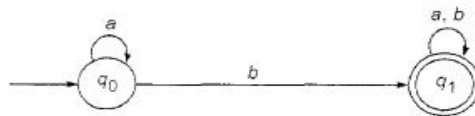

Given  $M = (\{q_0, q_1\}, \{a, b\}, \delta, q_0, \{q_1\})$

Construct  $G = (\{A_0, A_1\}, \{a, b\}, P, A_0)$  where  $P$  is given by

(i)  $A_i \rightarrow aA_j$  is included in  $P$  if  $\delta(q_i, a) = q_j \notin F$ .

$$\delta(q_0, a) = q_0 \notin F \Rightarrow A_0 \rightarrow aA_0$$

(ii)  $A_i \rightarrow aA_j$  and  $A_i \rightarrow a$  are included in  $P$  if  $\delta(q_i, a) = q_j \in F$ .

$$\delta(q_0, b) = q_1 \in F \Rightarrow A_0 \rightarrow bA_1 \text{ and } A_0 \rightarrow b$$

$$\delta(q_1, a) = q_1 \in F \Rightarrow A_1 \rightarrow aA_1 \text{ and } A_1 \rightarrow a$$

$$\delta(q_1, b) = q_1 \in F \Rightarrow A_1 \rightarrow bA_1 \text{ and } A_1 \rightarrow b$$

$\therefore P$  is given by

$$A_0 \rightarrow aA_0, \quad A_0 \rightarrow bA_1, \quad A_0 \rightarrow b$$

$$A_1 \rightarrow aA_1, \quad A_1 \rightarrow a, \quad A_1 \rightarrow bA_1, \quad A_1 \rightarrow b$$

**Steps to convert Finite Automata to Left Linear Grammar:**

**Step 1:** Reverse all the edges of the given automata and interchange initial state and final states.

**Step 2:** Represent the productions using Left Linear Grammar.

**Example:**

**2. Construct left linear grammar for the given DFA.**

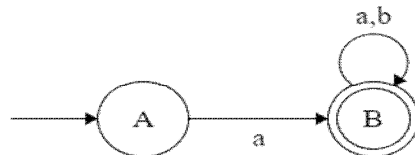

**Step 1:** Reverse all the edges of the given automata and interchange initial state and final states.

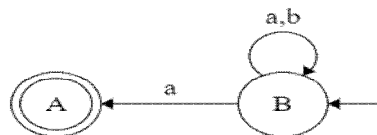

**Step 2:** Represent the productions using Left Linear Grammar.

$$\begin{array}{ll} B \rightarrow Ba & B \rightarrow Aa \\ B \rightarrow Bb & B \rightarrow a \end{array}$$

**4.1.2 Construction of a DFA for a given Regular Grammar:**

Let  $G = (\{A_0, A_1, \dots, A_n\}, \Sigma, P, A_0)$ . We construct a DFA  $M$  whose

- (i) states correspond to variables.
- (ii) initial state corresponds to  $A_0$ .
- (iii) transitions in  $M$  correspond to productions in  $P$ . As the last production applied in any derivation is of the form  $A_i \rightarrow a$ , the corresponding transition terminates at a new state, and this is the unique final state.

We define  $M$  as  $(\{q_0, q_1, \dots, q_n, q_f\}, \Sigma, \delta, q_0, \{q_f\})$  where  $\delta$  is defined as follows:

- (i) Each production  $A_i \rightarrow aA_j$  induces a transition from  $q_i$  to  $q_j$  with label  $a$ ,



(ii) Each production  $A_k \rightarrow a$  induces a transition from  $q_k$  to  $q_f$  with label  $a$ .

**Example:**

1.  $G = (\{A_0, A_1\}, \{a, b\}, P, A_0)$  where  $P$  consists of  $A_0 \rightarrow aA_1$ ,  $A_1 \rightarrow bA_1$ ,  $A_1 \rightarrow bA_0$ ,  $A_1 \rightarrow a$ . Construct a DFA  $M$  accepting  $L(G)$ .

$A_0 \rightarrow aA_1$  induces a transition from  $q_0$  to  $q_1$  with label  $a$ .

$A_1 \rightarrow bA_1$  induces a transition from  $q_1$  to  $q_1$  with label  $b$ .

$A_1 \rightarrow bA_0$  induces a transition from  $q_1$  to  $q_0$  with label  $b$ .

$A_1 \rightarrow a$  induces a transition from  $q_1$  to  $q_f$  with label  $a$ .

$M = (\{q_0, q_1, q_f\}, \Sigma, \delta, q_0, \{q_f\})$ , where  $q_0$  and  $q_f$  correspond to  $A_0$  and  $A_1$  respectively and  $q_f$  is the new final state introduced.

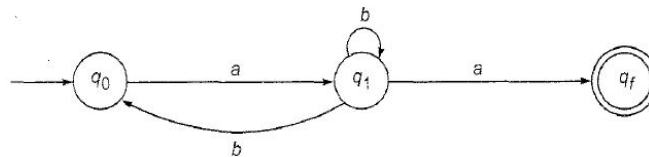

**2. Construct Finite Automata for the grammar which consists of the productions**

$$A \rightarrow aB \mid bA \mid b$$

$$B \rightarrow aC \mid bB$$

$$C \rightarrow aA \mid bC \mid a$$

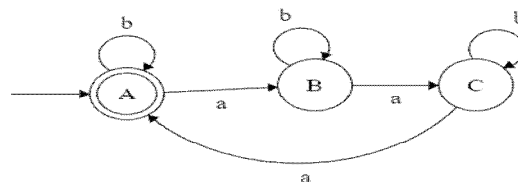

**4.2 Context-Free Grammar:**

A context-free grammar (CFG or just grammar) is denoted  $G = (V, T, P, S)$ , where

- $V$  and  $T$  are finite sets of variables and terminals, respectively.
- $P$  is a finite set of productions; each production is of the form  $A \rightarrow \alpha$ , where  $A$  is a variable and  $\alpha$  is a string of symbols from  $(V \cup T)^*$ .

- S is a special variable called the start symbol.

The language generated by G [denoted  $L(G)$ ] is  $\{w \mid w \text{ is in } T^* \text{ and } S \xRightarrow{*} w\}$ .

That is, a string is in  $L(G)$  if:

- 1) The string consists solely of terminals.
- 2) The string can be derived from S.

We call L a context-free language (CFL) if it is  $L(G)$  for some CFG G.

**Note: C language is an example for Context Free Language.**

**Examples:**

1. Write CFG for the language  $L = \{a^n b^n \mid n \geq 1\}$ .

$L = \{ab, aabb, aaabbb, aaaabbbb, aaaaabbbbb, \dots\}$

$G = (\{S\}, \{a, b\}, P, S)$

P:  $S \rightarrow aSb \mid ab$

(Or)

$S \rightarrow aSB$

$S \rightarrow aB$

$B \rightarrow b$

2. Write CFG for the language  $L = \{a^n b^m \mid n, m \geq 1\}$ .

$L = \{a, b, ab, aab, abb, aabb, aaabbb, aaaaabbbb, \dots\}$

$G = (\{S, A, B\}, \{a, b\}, P, S)$

P:  $S \rightarrow AB$

$A \rightarrow aA \mid a$

$B \rightarrow bB \mid b$

3. Write CFG for the language  $L = \{aa, ab, ba, bb\}$

$G = (\{S, A\}, \{a, b\}, P, S)$

P:  $S \rightarrow AA$

$A \rightarrow a \mid b$

4. Write CFG for the language  $L = \{a^n \mid n \geq 0\}$ .

$$L = \{ \epsilon, a, aa, aaa, aaaa, aaaaa, aaaaaa, \dots \}$$

$$G = (\{A\}, \{a\}, P, A)$$

$$P: \quad A \rightarrow aA \mid \epsilon$$

5. Write CFG for the regular expression  $(a+b)^*$ .

$$L = \{ \epsilon, a, b, aa, ab, ba, bb, aaa, abb, aba, \dots \}$$

$$G = (\{S\}, \{a, b\}, P, S)$$

$$P: \quad S \rightarrow aS \mid bS \mid \epsilon$$

6. Write CFG to generate all strings of  $\{a, b\}$  whose length is atleast 2.

$$L = \{ aa, ab, ba, bb, aaa, abb, aba, \dots \}$$

$$G = (\{S, A, B\}, \{a, b\}, P, S)$$

$$P: \quad S \rightarrow AAB$$

$$A \rightarrow a \mid b$$

$$B \rightarrow aB \mid bB \mid \epsilon$$

7. Write CFG to generate all strings of  $\{a, b\}$  whose length is atleast 2.

$$L = \{ \epsilon, a, b, aa, ab, ba, bb \}$$

$$G = (\{S, A\}, \{a, b\}, P, S)$$

$$P: \quad S \rightarrow AA$$

$$A \rightarrow a \mid b \mid \epsilon$$

8. Write CFG to generate palindromes over  $\{a, b\}$ .

$$L = \{ \epsilon, a, b, aa, bb, aba, bab, aaaa, abba, \dots \}$$

$$G = (\{S\}, \{a, b\}, P, S)$$

$$P: \quad S \rightarrow aSa \mid bSb$$

$$S \rightarrow a \mid b \mid \epsilon$$

9. Write CFG to generate equal number of a's and b's.

$$L = \{ ab, ba, aabb, abab, bbaa, baba, \dots \}$$

$$G = (V, T, P, S), \text{ where } V = \{S, A, B\}, T = \{a, b\}, S \text{ and } P.$$

$$P: \quad S \rightarrow aB \quad A \rightarrow bAA$$

$$S \rightarrow bA \quad B \rightarrow b$$

$$\begin{array}{ll} A \rightarrow a & B \rightarrow bS \\ A \rightarrow aS & B \rightarrow aBB \end{array}$$

**Sentential Form:**

A string of terminals and variables  $\alpha$  is called a sentential form if  $S \xRightarrow{*} \alpha$ .

**Derivation:**

Derivation is the process of applying productions repeatedly to expand non-terminals in terms of terminals or non-terminals, until there are no more non-terminals.

**A derivation can be either Leftmost derivation or Right most derivation.**

**Leftmost derivation:**

If at each step in a derivation a production is applied to the leftmost variable, then the derivation is said to be leftmost.

**Example:**

Consider the grammar  $G = (\{S, A\}, \{a, b\}, P, S)$ , where  $P$  consists of

$$\begin{array}{l} S \rightarrow aAS \mid a \\ A \rightarrow SbA \mid SS \mid ba \end{array}$$

The corresponding leftmost derivation is

$$S \Rightarrow aAS \Rightarrow aSbAS \Rightarrow aabAS \Rightarrow aabbaS \Rightarrow aabbaa.$$

**Rightmost derivation:**

A derivation in which the rightmost variable is replaced at each step is said to be rightmost.

**Example:**

Consider the grammar  $G = (\{S, A\}, \{a, b\}, P, S)$ , where  $P$  consists of

$$\begin{array}{l} S \rightarrow aAS \mid a \\ A \rightarrow SbA \mid SS \mid ba \end{array}$$

The corresponding rightmost derivation is

$$S \Rightarrow aAS \Rightarrow aAa \Rightarrow aSbAa \Rightarrow aSbbaa \Rightarrow aabbaa.$$

**Note:**“If  $w$  is in  $L(G)$  for CFG  $G$ , then  $w$  has at least one parse tree, and corresponding to a particular parse tree,  $w$  has a unique leftmost and a unique rightmost derivation.”

### **4.3 Derivation Trees (or) Parse tree:**

The derivations in a CFG can be represented using trees. Such trees representing derivations are called derivation trees.

Let  $G = (V, T, P, S)$  be a CFG. A tree is a derivation (or parse) tree for  $G$  if:

- 1) Every vertex has a label, which is a symbol of  $V \cup T \cup \{\epsilon\}$ .
- 2) The label of the root is  $S$ .
- 3) If a vertex is interior and has label  $A$ , then  $A$  must be in  $V$ .
- 4) If  $n$  has label  $A$  and vertices  $n_1, n_2, n_3, \dots, n_k$  are the sons of vertex  $n$ , in order from the left, with labels  $X_1, X_2, \dots, X_k$ , respectively, then  $A \rightarrow X_1X_2 \dots X_k$  must be a production in  $P$ .
- 5) If vertex  $n$  has label  $\epsilon$ , then  $n$  is a leaf and is the only son of its father.

#### **Example:**

**Consider the grammar  $G = (\{S, A\}, \{a, b\}, P, S)$ , where  $P$  consists of**

$$S \rightarrow aAS \mid a$$

$$A \rightarrow SbA \mid SS \mid ba$$

**Construct a derivation tree for the string “aabbaa”**

A derivation tree is a natural description of the derivation of a particular sentential form of the grammar  $G$ . If we read the labels of the leaves from left to right, we have a sentential form. We call this string the yield of the derivation tree.

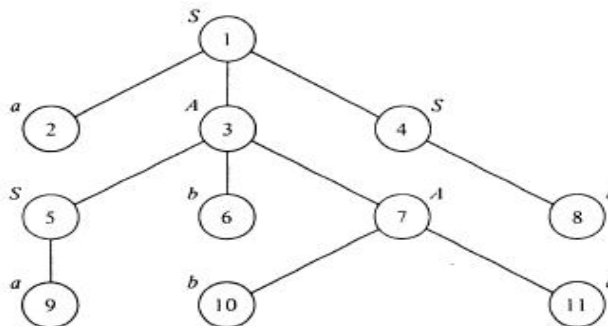

$S \Rightarrow aAS \Rightarrow aSbAS \Rightarrow aabAS \Rightarrow aabbaS \Rightarrow aabbaa.$

**Note:** Some leaves could be labelled by  $\epsilon$ .

## UNIT - IV

### Assignment-Cum-Tutorial Questions

#### SECTION-A

#### Objective Questions

1. The C language is [     ]  
 a) A context free language                      b) A context sensitive language  
 c) A regular language                                d) None
  
2. Every regular grammar is context free grammar. (True     |  
False)
  
3. The finite automata accepts the following language: [     ]  
 a) Context free language                            b) regular language  
 c) Context sensitive language                      d) all of the above
  
4. Context-free grammar can be recognized by [     ]  
 a) Finite Automata                                    b) Linear bounded Automata  
 c) Push down Automata                              d) both (b) and (c)
  
5. The language accepted by a Turing Machine: [     ]  
 a) Type 0                      b) Type 1                      c) Type 2                      d) Type 3
  
6. Match the following  
 1. Context Free Language                            a. Turing Machine                      [     ]  
 2. Recursively Enumerable                        b. Finite Automata                      [     ]  
 3. Regular Language                                    c. Linear Bounded Automata [     ]  
 4. Context Sensitive Language                    d. Push Down Automata [     ]
  
7. For every right linear grammar, there will be an equivalent FA. [True/ False]
  
8. Recursively Enumerable language is also called as \_\_\_\_\_.
  
9. A context free grammar is [     ]  
 a) Type 0                      b) Type 1                      c) Type 2                      d) Type 3
  
10. Which word can be generated by  $S \rightarrow d | bA, A \rightarrow d | ccA$  [     ]  
 a) bccccd                      b) aabccd                      c) ababccd                      d) abbbd
  
11. Which of the following strings is in the language defined by grammar  $S \rightarrow 0A, A \rightarrow 1A | 0A | 1$  [     ]  
 a) 01100                      b) 00101                      c) 10011                      d) 11111
  
12. Recognize the CFL for the given CFG. [     ]  
 $S \rightarrow aB | bA,$   
 $A \rightarrow a | aS | bAA,$   
 $B \rightarrow b | bS | aBB$   
 a) strings contain equal number of a's and equal number of b's.

- b) strings contain odd number of a's and odd number of b's.  
 c) strings contain odd number of a's and even number of b's.  
 d) strings contain even number of a's and even number of b's
13. Given the following productions of a grammar: [      ]  
 $S \rightarrow aA \mid aBB$      $A \rightarrow aaA \mid \epsilon$      $B \rightarrow bB \mid bbC$      $C \rightarrow B$   
 Which of the following is true?  
 a) The language corresponding to the given grammar is a set of even number of a's.  
 b) The language corresponding to the given grammar is a set of odd number of a's.  
 c) The language corresponding to the given grammar is a set of even number of a's followed by odd number of b's.  
 d) The language corresponding to the given grammar is a set of odd number of a's followed by even number of b's.
14. A regular grammar for the language  $L = \{ a^n b^m \mid n \text{ is even and } m \text{ is even} \}$  is [      ]  
 a)  $S \rightarrow aSb \mid X; X \rightarrow bXa \mid \epsilon$   
 b)  $S \rightarrow aaS \mid X; X \rightarrow bSb \mid \epsilon$   
 c)  $S \rightarrow aSb \mid X; X \rightarrow Xab \mid \epsilon$   
 d)  $S \rightarrow aaS \mid X; X \rightarrow bbX \mid \epsilon$
15. Which of the regular expressions corresponds to this grammar?  
 $S \rightarrow AB \mid AS$      $A \rightarrow a \mid aA$      $B \rightarrow b$  [      ]  
 a)  $(aa)^*b$     b)  $aa^*b$     c)  $(ab)^*$   
 d)  $a(ab)^*$
16. Identify the language generated by the following grammar [      ]  
 $S \rightarrow aS \mid bS \mid abA$   
 $A \rightarrow aA \mid bA \mid \epsilon$   
 a)  $L = x \mid ab \text{ is a substring of } x, x \in \{a,b\}^*$   
 b)  $L = x \mid a \text{ is a substring of } x, x \in \{a,b\}^*$   
 c)  $L = x \mid b \text{ is a substring of } x, x \in \{a,b\}^*$   
 d)  $L = x \mid ba \text{ is a substring of } x, x \in \{a,b\}^*$
17. The CFG  $S \rightarrow aS \mid bS \mid a \mid b$  is equivalent to the regular expression  
 a)  $(a^*+b)^*$     b)  $(a+b)^*$     c)  $(a+b)(a+b)^*$     d)  $(a+b)(a+b)$  [      ]
18. The regular grammar for the given FA is [      ]

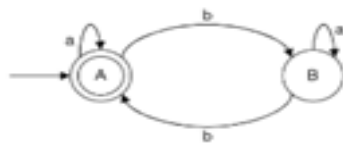

- a)  $A \rightarrow aA \mid bB \mid a$     c)  $A \rightarrow aA \mid bB \mid b$



$$\begin{array}{ll}
 B \rightarrow bA \mid aB \mid b & B \rightarrow bA \mid aB \mid a \\
 \text{b) } A \rightarrow aA \mid bB \mid \varepsilon & \text{d) } A \rightarrow bA \mid aB \mid a \\
 B \rightarrow bA \mid aB \mid \varepsilon & B \rightarrow aA \mid bB \mid b
 \end{array}$$

## SECTION-B

### Descriptive questions

- Sketch the Venn diagram of Chomsky hierarchy language and their counterpart automata.
- Define Regular grammar with an example.
- What is sentential form? Explain with an example.
- Explain derivation tree with an example.
- Explain left most derivation and right most derivation with examples.
- Define Context Free Grammar and obtain CFG for:
  - the set of all strings with odd palindromes over alphabet  $\{0,1\}$
  - the set of all strings over alphabet  $\{a, b\}$  with exactly twice as many a's as b's.
  - balanced parenthesis
- Show that **id+id\*id** can be generated by two distinct derivation trees for the grammar:
 
$$E \rightarrow E+E \mid E^*E \mid (E) \mid id$$
- Let G be the grammar
 
$$\begin{array}{l}
 S \rightarrow aB \mid bA \\
 A \rightarrow a \mid aS \mid bAA \\
 B \rightarrow b \mid bS \mid aBB.
 \end{array}$$
 For the string aaabbabbba find a
  - Left most derivation
  - Right most derivation
  - Parse Tree
- Obtain the right linear grammar for the following FA.

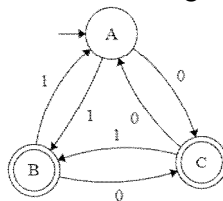

- Obtain a Right Linear Grammar for the language  $L = \{a^n b^m \mid n \geq 2, m \geq 3\}$
- Convert the following DFA to Regular grammar

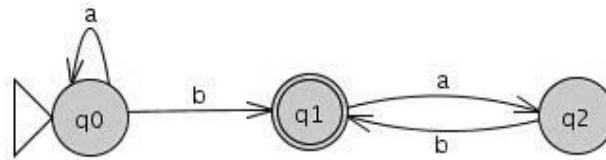

12. Is the following grammar ambiguous?  
 $S \rightarrow AB|aaB$   
 $A \rightarrow > a|Aa$   
 $B \rightarrow b$
13. Find the language generated by the following grammar.  
 $S \rightarrow SS \quad S \rightarrow aa \quad S \rightarrow \epsilon$
14. Draw a derivation tree for the string abaaba for the CFG given by  $G$  where  $P = \{S \rightarrow aSa \mid S \rightarrow bSb \mid S \rightarrow a \mid b \mid \epsilon\}$
15. Obtain a right linear grammar and left linear grammar for the following FA.

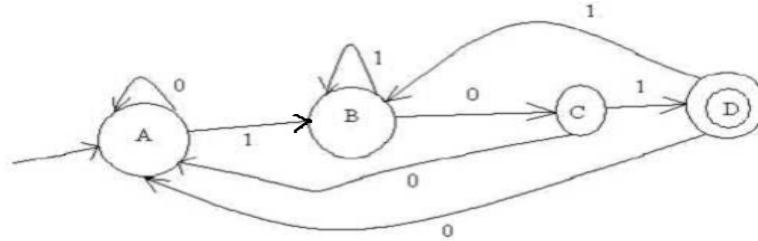

**SECTION-C**

**Gate Questions**

1.  $G1: S \rightarrow aS \mid B, B \rightarrow b \mid bB$  **[GATE 2016]**

$G2: S \rightarrow aA \mid bB; A \rightarrow aA \mid B \mid \square, B \rightarrow bB \mid \square$

Which one of the following pairs of languages is generated by  $G1$  and  $G2$ , respectively? [     ]

- a)  $\{a^m b^n \mid m > 0 \text{ or } n > 0\}$  and  $\{a^m b^n \mid m > 0 \text{ and } n > 0\}$
- b)  $\{a^m b^n \mid m > 0 \text{ and } n > 0\}$  and  $\{a^m b^n \mid m > 0 \text{ or } n > = 0\}$
- c)  $\{a^m b^n \mid m > = 0 \text{ or } n > 0\}$  and  $\{a^m b^n \mid m > 0 \text{ and } n > 0\}$
- d)  $\{a^m b^n \mid m > = 0 \text{ and } n > 0\}$  and  $\{a^m b^n \mid m > 0 \text{ or } n > 0\}$

2.  $S \rightarrow aSa \mid bSb \mid a \mid b$  [     ] **[GATE 2009]**

The language generated by the above grammar over the alphabet  $\{a, b\}$  is the of

- a) all palindromes
- b) all odd length palindromes
- c) strings that begin and
- d) all even length palindromes     end with the same symbol

3. Consider the CFG with  $\{S,A,B\}$  as the non-terminal alphabet  $\{a,b\}$  as the terminal alphabet,  $S$  as the start symbol and the following set of production rules: **[GATE 2007]**

$$\begin{array}{ll} S \rightarrow aB & S \rightarrow bA \\ B \rightarrow b & A \rightarrow a \\ B \rightarrow bS & A \rightarrow aS \\ B \rightarrow aBB & S \rightarrow bAA \end{array}$$

Which of the following strings is generated by the grammar? [      ]

a) aaaabb      b) aabbbb      c) aabbab      d) abbbba

4. How many derivation trees are there for the grammar in Question 3?

a) 1      b) 2      c) 3      d) 4      [      ]

5. Consider the regular grammar:

[GATE 2005]

$$\begin{array}{l} S \rightarrow Xa | Ya \\ X \rightarrow Za \\ Z \rightarrow Sa | \square \\ Y \rightarrow Wa \\ W \rightarrow Sa \end{array}$$

where S is the starting symbol, the set of terminals is {a} and the set of non-terminals is {S, W, X, Y, Z}. We wish to construct a deterministic finite automaton (DFA) to recognize the same language. What is the minimum number of states required for the DFA?

a) 2      b) 3      c) 4      d) 5

6.

[GATE 2005]

Which one of the following grammars generates the language  $L = \{a^i b^j | i \neq j\}$ ?

(A)

$$\begin{array}{l} S \rightarrow AC | CB \\ C \rightarrow aC b | a | b \\ A \rightarrow aA | \epsilon \\ B \rightarrow Bb | \epsilon \end{array}$$

(B)  $S \rightarrow aS | Sb | a | b$

(C)

$$\begin{array}{l} S \rightarrow AC | CB \\ C \rightarrow aC b | \epsilon \\ A \rightarrow aA | \epsilon \\ B \rightarrow Bb | \epsilon \end{array}$$

(D)

$$\begin{array}{l} S \rightarrow AC | CB \\ C \rightarrow aC b | \epsilon \\ A \rightarrow aA | a \\ B \rightarrow Bb | b \end{array}$$

## UNIT-V

### **Objective:**

To understand and design push down automata's for a given Context free language.

### **Syllabus:**

Ambiguity in context free grammars, minimization of Context Free Grammars, Chomsky normal form, Greibach normal form, pumping lemma for Context Free Languages, closure properties of CFL (proofs not required), applications of CFLs

### **Push down automata:**

Push down automata, model of PDA, design of PDA.

### **Learning Outcomes:**

Students will be able to:

- understand ambiguity in context free grammars.
- minimize the given context free grammar.
- apply Chomsky and Greibach Normal Forms on context free grammars.
- understand and design PDA for given context free languages.

### **Learning Material**

#### **5.1 Ambiguity in context free grammars:**

A context-free grammar  $G$  is said to be ambiguous if it has two parse trees for some word.

(or)

A word which has more than one leftmost derivation or more than one rightmost derivation is said to be ambiguous.

**Note:** A CFL for which every CFG is ambiguous is said to be an inherently ambiguous CFL.

**Example:**

$G = (\{S\}, \{a, b, +, *\}, P, S)$ , where  $P$  consists of  $S \rightarrow S+S \mid S*S \mid a \mid b$

We have two derivation trees for  $a + a * b$

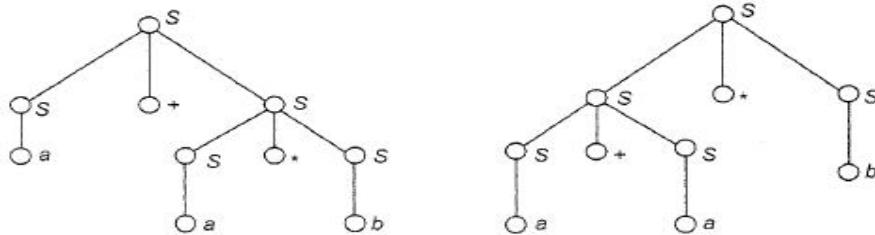

Two derivation trees for  $a + a * b$

**5.2 Minimization of Context Free Grammars:**

- 1) Elimination of useless symbols.
- 2) Elimination of  $\epsilon$  -Productions.
- 3) Elimination of Unit Productions.

**Elimination of Useless Symbols:**

Let  $G=(V, T, P, S)$  be a grammar. A symbol  $X$  is useless if it is not involved in derivation.

(or)

A symbol  $X$  is useless if there is no way of getting a terminal string from it.

**Example:**

Consider the grammar

$$S \rightarrow AB \mid a$$

$$A \rightarrow a$$

We find that no terminal string is derivable from  $B$ . We therefore eliminate  $B$  and the production  $S \rightarrow AB$ .

Then the grammar is

$$S \rightarrow a$$

$$A \rightarrow a$$

We find that only S and a appear in sentential forms. Thus  $(\{S\}, \{a\}, \{S \rightarrow a\}, S)$  is an equivalent grammar with no useless symbols.

### **Elimination of $\epsilon$ -Productions:**

A production of the form  $A \rightarrow \epsilon$ , where A is a variable, is called a *null production*.

If  $L = L(G)$  for some CFG  $G = (V, T, P, S)$ , then  $L - \{\epsilon\}$  is  $L(G')$  for a CFG  $G'$  with no useless symbols or  $\epsilon$  -productions.

### ***Example:***

Consider the grammar

$$A \rightarrow 0B1 \mid 1B1$$

$$B \rightarrow 0B \mid 1B \mid \epsilon$$

Remove  $\epsilon$ -productions from the grammar.

$B \rightarrow \epsilon$  is the null production.

The new productions after elimination of  $\epsilon$  are

$$A \rightarrow 0B1 \mid 1B1 \mid 01 \mid 11$$

$$B \rightarrow 0B \mid 1B \mid 0 \mid 1$$

### **Elimination of Unit Productions:**

A production of the form  $A \rightarrow B$  whose right-hand side consists of a single variable is called a unit production.

All other productions, including those of the form  $A \rightarrow a$  and  $\epsilon$  -productions, are nonunit productions.

### ***Example:***

Consider the grammar

$$S \rightarrow 0A \mid 1B \mid C$$

$$A \rightarrow 0S \mid 00$$

$$B \rightarrow 1 \mid A$$

$$C \rightarrow 01$$

Remove unit production from the grammar.

$S \rightarrow C$  and  $B \rightarrow A$  are the unit productions

The new productions after elimination of unit productions are

$$S \rightarrow 0A \mid 1B \mid 01$$

$$A \rightarrow 0S \mid 00$$

$$B \rightarrow 1 \mid 0S \mid 00$$

$$C \rightarrow 01$$

C is a useless symbol. So eliminate C production.

The final set of productions are

$$S \rightarrow 0A \mid 1B \mid 01$$

$$A \rightarrow 0S \mid 00$$

$$B \rightarrow 1 \mid 0S \mid 00$$

### **5.3 Chomsky Normal Form :( CNF)**

Any context-free language without  $\epsilon$  is generated by a grammar in which all productions are of the form  $A \rightarrow BC$  or  $A \rightarrow a$ . Here, A, B, and C, are variables and a is a terminal.

**Step 1:** Simplify the grammar.

- a) Eliminate  $\epsilon$  -productions
- b) Eliminate unit productions
- c) Eliminate Useless symbols.

The given grammar does not contain  $\epsilon$  -productions, unit productions and useless symbols.

It is in optimized form.

**Step 2:** Consider a production in P, of the form  $A \rightarrow X_1 X_2 X_3 \dots X_m$  where  $m \geq 2$ . If  $X_i$  is a terminal a, introduce a new variable  $C_a$  and a production  $C_a \rightarrow a$ . Then replace  $X_i$  by  $C_a$ .

**Step 3:** Consider a production  $A \rightarrow B_1 B_2 B_3 \dots B_m$  where  $m \geq 3$ , create new variables  $D_1, D_2, \dots, D_{m-2}$  and replace  $A \rightarrow B_1 B_2 B_3 \dots B_m$  by the set of productions  $\{A \rightarrow B_1 D_1, D_1 \rightarrow B_2 D_2, \dots, D_{m-3} \rightarrow B_{m-2} D_{m-2}, D_{m-2} \rightarrow B_{m-1} B_m\}$

**Example:**

Consider the grammar  $(\{S, A, B\}, \{a, b\}, P, S)$  that has the productions:

$$S \rightarrow bA \mid aB$$

$$A \rightarrow bAA \mid aS \mid a$$

$$B \rightarrow aBB \mid bS \mid b$$

Find an equivalent grammar in CNF.

**Step 1:** Simplify the grammar.

- a) Eliminate  $\epsilon$ -productions
- b) Eliminate unit productions
- c) Eliminate Useless symbols.

The given grammar does not contain  $\epsilon$ -productions, unit productions and useless symbols.

It is in optimized form.

**Step 2:** The only productions already in proper form are  $A \rightarrow a$  and  $B \rightarrow b$ .

So we may begin by replacing terminals on the right by variables, except in the case of the productions  $A \rightarrow a$  and  $B \rightarrow b$ .

$S \rightarrow bA$  is replaced by  $S \rightarrow C_b A$  and  $C_b \rightarrow b$ .

Similarly,  $A \rightarrow aS$  is replaced by  $A \rightarrow C_a S$  and  $C_a \rightarrow a$ ;  $A \rightarrow bAA$  is replaced by  $A \rightarrow C_b AA$ ;  $S \rightarrow aB$  is replaced by  $S \rightarrow C_a B$ ;

$B \rightarrow bS$  is replaced by  $B \rightarrow C_b S$ , and  $B \rightarrow aBB$  is replaced by  $B \rightarrow C_a BB$ .

In the next stage, the production  $A \rightarrow C_b AA$  is replaced by  $A \rightarrow C_b D_1$  and  $D_1 \rightarrow AA$ , and the production  $B \rightarrow C_a BB$  is replaced by  $B \rightarrow C_a D_2$  and  $D_2 \rightarrow BB$ .

**Step 3:** The productions for the grammar in CNF are :

$$S \rightarrow C_b A \mid C_a B \quad D_1 \rightarrow AA$$

$$A \rightarrow C_a S \mid C_b D_1 \mid a D_2 \rightarrow BB$$

$$B \rightarrow C_b S \mid C_a D_2 \mid b \quad C_a \rightarrow a$$

$$C_b \rightarrow b$$



### **5.4 Greibach Normal Form:**

Every context-free language  $L$  without  $\epsilon$  can be generated by a grammar for which every production is of the form  $A \rightarrow a\alpha$ , where  $A$  is a variable,  $a$  is a terminal, and  $\alpha$  is a (possibly empty) string of variables.

**Lemma 1:** Define an  $A$ -production to be a production with variable  $A$  on the left. Let  $G = (V, T, P, S)$  be a CFG. Let  $A \rightarrow \alpha_1 B \alpha_2$  be a production in  $P$  and  $B \rightarrow \beta_1 \mid \beta_2 \mid \dots \mid \beta_r$  be the set of all  $B$ -productions. Let  $G_1 = (V, T, P_1, S)$  be obtained from  $G$  by deleting the production  $A \rightarrow \alpha_1 B \alpha_2$  from  $P$  and adding the productions  $A \rightarrow \alpha_1 \beta_1 \alpha_2 \mid \alpha_1 \beta_2 \alpha_2 \mid \dots \mid \alpha_1 \beta_r \alpha_2$ . Then  $L(G) = L(G_1)$ .

**Lemma 2:** Let  $G = (V, T, P, S)$  be a CFG. Let  $A \rightarrow A\alpha_1 \mid A\alpha_2 \mid \dots \mid A\alpha_r$  be the set of  $A$ -productions for which  $A$  is the leftmost symbol of the right-hand side. Let  $A \rightarrow \beta_1 \mid \beta_2 \mid \dots \mid \beta_s$  be the remaining  $A$ -productions. Let  $G_1 = (V \cup \{B\}, T, P_1, S)$  be the CFG formed by adding the variable  $B$  to  $V$  and replacing all the  $A$ -productions by the productions:

$$1) \left. \begin{array}{l} A \rightarrow \beta_i \\ A \rightarrow \beta_i B \end{array} \right\} 1 \leq i \leq s, \quad 2) \left. \begin{array}{l} B \rightarrow \alpha_i \\ B \rightarrow \alpha_i B \end{array} \right\} 1 \leq i \leq r.$$

Then  $L(G_1) = L(G)$ .

### ***Example:***

Convert to Greibach normal form the grammar

$G = (V, T, P, S)$ ,  $V = \{A_1, A_2, A_3\}$ ,  $T = \{a, b\}$ ,  $P = \{A_1\}$ ,

where  $P$  consists of the following:

$$\begin{aligned}A_1 &\rightarrow A_2 A_3 \\A_2 &\rightarrow A_3 A_1 | b \\A_3 &\rightarrow A_1 A_2 | a\end{aligned}$$

*Step 1* Since the right-hand side of the productions for  $A_1$  and  $A_2$  start with terminals or higher-numbered variables, we begin with the production  $A_3 \rightarrow A_1 A_2$  and substitute the string  $A_2 A_3$  for  $A_1$ . Note that  $A_1 \rightarrow A_2 A_3$  is the only production with  $A_1$  on the left.

The resulting set of productions is:

$$\begin{aligned}A_1 &\rightarrow A_2 A_3 \\A_2 &\rightarrow A_3 A_1 | b \\A_3 &\rightarrow A_2 A_3 A_2 | a\end{aligned}$$

Since the right side of the production  $A_3 \rightarrow A_2 A_3 A_2$  begins with a lower-numbered variable, we substitute for the first occurrence of  $A_2$  both  $A_3 A_1$  and  $b$ . Thus  $A_3 \rightarrow A_2 A_3 A_2$  is replaced by  $A_3 \rightarrow A_3 A_1 A_3 A_2$  and  $A_3 \rightarrow b A_3 A_2$ . The new set is

$$\begin{aligned}A_1 &\rightarrow A_2 A_3 \\A_2 &\rightarrow A_3 A_1 | b \\A_3 &\rightarrow A_3 A_1 A_3 A_2 | b A_3 A_2 | a\end{aligned}$$

We now apply Lemma 2 to the productions

$$A_3 \rightarrow A_3 A_1 A_3 A_2 | b A_3 A_2 | a.$$

Symbol  $B_3$  is introduced, and the production  $A_3 \rightarrow A_3 A_1 A_3 A_2$  is replaced by  $A_3 \rightarrow b A_3 A_2 B_3$ ,  $A_3 \rightarrow a B_3$ ,  $B_3 \rightarrow A_1 A_3 A_2$ , and  $B_3 \rightarrow A_1 A_3 A_2 B_3$ . The resulting set is

$$\begin{aligned}A_1 &\rightarrow A_2 A_3 \\A_2 &\rightarrow A_3 A_1 | b \\A_3 &\rightarrow b A_3 A_2 B_3 | a B_3 | b A_3 A_2 | a \\B_3 &\rightarrow A_1 A_3 A_2 | A_1 A_3 A_2 B_3\end{aligned}$$

**Step 2** Now all the productions with  $A_3$  on the left have right-hand sides that start with terminals. These are used to replace  $A_3$  in the production  $A_2 \rightarrow A_3 A_1$  and then the productions with  $A_2$  on the left are used to replace  $A_2$  in the production  $A_1 \rightarrow A_2 A_3$ . The result is the following.

$$\begin{array}{ll}
 A_3 \rightarrow bA_3 A_2 B_3 & A_3 \rightarrow bA_3 A_2 \\
 A_3 \rightarrow aB_3 & A_3 \rightarrow a \\
 A_2 \rightarrow bA_3 A_2 B_3 A_1 & A_2 \rightarrow bA_3 A_2 A_1 \\
 A_2 \rightarrow aB_3 A_1 & A_2 \rightarrow aA_1 \\
 A_2 \rightarrow b & \\
 A_1 \rightarrow bA_3 A_2 B_3 A_1 A_3 & A_1 \rightarrow bA_3 A_2 A_1 A_3 \\
 A_1 \rightarrow aB_3 A_1 A_3 & A_1 \rightarrow aA_1 A_3 \\
 A_1 \rightarrow bA_3 & \\
 B_3 \rightarrow A_1 A_3 A_2 & B_3 \rightarrow A_1 A_3 A_2 B_3
 \end{array}$$

**Step 3** The two  $B_3$ -productions are converted to proper form, resulting in  $\cup$  more productions. That is, the productions

$$B_3 \rightarrow A_1 A_3 A_2 \quad \text{and} \quad B_3 \rightarrow A_1 A_3 A_2 B_3$$

are altered by substituting the right side of each of the five productions with  $A_1$  on the left for the first occurrences of  $A_1$ . Thus  $B_3 \rightarrow A_1 A_3 A_2$  becomes

$$B_3 \rightarrow bA_3 A_2 B_3 A_1 A_3 A_3 A_2, \quad B_3 \rightarrow aB_3 A_1 A_3 A_3 A_2.$$

$$B_3 \rightarrow bA_3 A_3 A_2, \quad B_3 \rightarrow bA_3 A_2 A_1 A_3 A_3 A_2, \quad B_3 \rightarrow aA_1 A_3 A_3 A_2.$$

The other production for  $B_3$  is replaced similarly. The final set of productions is

$$\begin{array}{ll}
 A_3 \rightarrow bA_3 A_2 B_3 & A_3 \rightarrow bA_3 A_2 \\
 A_3 \rightarrow aB_3 & A_3 \rightarrow a \\
 A_2 \rightarrow bA_3 A_2 B_3 A_1 & A_2 \rightarrow bA_3 A_2 A_1 \\
 A_2 \rightarrow aB_3 A_1 & A_2 \rightarrow aA_1 \\
 A_2 \rightarrow b & \\
 A_1 \rightarrow bA_3 A_2 B_3 A_1 A_3 & A_1 \rightarrow bA_3 A_2 A_1 A_3 \\
 A_1 \rightarrow aB_3 A_1 A_3 & A_1 \rightarrow aA_1 A_3 \\
 A_1 \rightarrow bA_3 & \\
 B_3 \rightarrow bA_3 A_2 B_3 A_1 A_3 A_3 A_2 B_3 & B_3 \rightarrow bA_3 A_2 B_3 A_1 A_3 A_3 A_2 \\
 \\
 B_3 \rightarrow aB_3 A_1 A_3 A_3 A_2 B_3 & B_3 \rightarrow aB_3 A_1 A_3 A_3 A_2 \\
 B_3 \rightarrow bA_3 A_3 A_2 B_3 & B_3 \rightarrow bA_3 A_3 A_2 \\
 B_3 \rightarrow bA_3 A_2 A_1 A_3 A_3 A_2 B_3 & B_3 \rightarrow bA_3 A_2 A_1 A_3 A_3 A_2 \\
 B_3 \rightarrow aA_1 A_3 A_3 A_2 B_3 & B_3 \rightarrow aA_1 A_3 A_3 A_2
 \end{array}$$

### **5.5 Pumping Lemma for CFL's:**

Let  $L$  be any CFL. Then there is a constant  $n$ , depending only on  $L$ , such that if  $z$  is in  $L$  and  $|z| \geq n$ , then we may write  $z = uvwxy$  such that

- 1)  $|vx| \geq 1$ ,
- 2)  $|vwx| \leq n$ , and
- 3) for all  $i \geq 0$   $uv^iwx^iy$  is in  $L$ .

#### ***Example:***

Consider the language  $L = \{a^ib^ic^i \mid i \geq 1\}$ . Suppose  $L$  were context free and let  $n$  be the constant.

Consider  $z = a^n b^n c^n$ . Write  $z = uvwxy$  so as to satisfy the conditions of the pumping lemma.

Since  $|vwx| \leq n$ , it is not possible for  $vx$  to contain instances of  $a$ 's and  $c$ 's, because the rightmost  $a$  is  $n + 1$  positions away from the leftmost  $c$ .

If  $v$  and  $x$  consist of  $a$ 's only, then  $uw^i$  (the string  $uv^iwx^iy$  with  $i = 0$ ) has  $n$   $b$ 's and  $n$   $c$ 's but fewer than  $n$   $a$ 's since  $|vx| \geq 1$ .

Thus,  $uw^i$  is not of the form  $a^ib^ic^i$ . But by the pumping lemma  $uw^i$  is in  $L$ , a contradiction.

The cases where  $v$  and  $x$  consist only of  $b$ 's or only of  $c$ 's are disposed of similarly.

If  $vx$  has  $a$ 's and  $b$ 's, then  $uw^i$  has more  $c$ 's than  $a$ 's or  $b$ 's, and again it is not in  $L$ .

If  $vx$  contains  $b$ 's and  $c$ 's, a similar contradiction results.

We conclude that  $L$  is not a context-free language.

### **5.6 Closure Properties of CFL's:**

- Context-free languages are closed under union, concatenation and Kleene closure.
- The context-free languages are closed under substitution.
- The CFL's are closed under homomorphism.
- The CFL's are not closed under intersection.
- The CFL's are not closed under complementation.

### **Applications of the pumping lemma:**

The pumping lemma can be used to prove a variety of languages not to be context free, using the same "adversary" argument as for the regular set pumping lemma.

### **5.7 Push down automata:**

A *pushdown automaton*  $M$  is a system  $(Q, \Sigma, \Gamma, \delta, q_0, Z_0, F)$ , where

- 1)  $Q$  is a finite set of *states*;
- 2)  $\Sigma$  is an alphabet called the *input alphabet*;
- 3)  $\Gamma$  is an alphabet, called the *stack alphabet*;
- 4)  $q_0$  in  $Q$  is the *initial state*;
- 5)  $Z_0$  in  $\Gamma$  is a particular stack symbol called the *start symbol*;
- 6)  $F \subseteq Q$  is the set of *final states*;
- 7)  $\delta$  is a mapping from  $Q \times (\Sigma \cup \{\epsilon\}) \times \Gamma$  to finite subsets of  $Q \times \Gamma^*$ .

### **Moves:**

The interpretation of

$$\delta(q, a, Z) = \{(p_1, \gamma_1), (p_2, \gamma_2), \dots, (p_m, \gamma_m)\}$$

where  $q$  and  $p_i$ ,  $1 \leq i \leq m$ , are states,  $a$  is in  $\Sigma$ ,  $Z$  is a stack symbol, and  $\gamma_i$  is in  $\Gamma^*$ ,  $1 \leq i \leq m$ , is that the PDA in state  $q$ , with input symbol  $a$  and  $Z$  the top symbol on the stack can, for any  $i$ , enter state  $p_i$ , replace symbol  $Z$  by string  $\gamma_i$ , and advance the input head one symbol. We adopt the convention that the leftmost symbol of  $\gamma_i$  will be placed highest on the stack and the rightmost symbol lowest on the stack. Note that it is not permissible to choose state  $p_i$  and string  $\gamma_j$  for some  $j \neq i$  in one move.

The interpretation of

$$\delta(q, \epsilon, Z) = \{(p_1, \gamma_1), (p_2, \gamma_2), \dots, (p_m, \gamma_m)\}$$

is that the PDA in state  $q$ , independent of the input symbol being scanned and with  $Z$  the top symbol on the stack, can enter state  $p_i$  and replace  $Z$  by  $\gamma_i$  for any  $i$ ,  $1 \leq i \leq m$ . In this case, the input head is not advanced.

**Model of PDA:**

- Pushdown automaton has a read-only input tape, an input alphabet a finite state control, a set of final states, and an initial state as in the case of an FA.
- In addition to these, it has a stack called the pushdown store. It is a read-write pushdown store as we can add elements to PDS or remove elements from PDS.
- A finite automaton is in some state and on reading, an input symbol moves to a new state.
- The pushdown automaton is also in some state and on reading an input symbol and the topmost symbol in PDS, it moves to a new state and writes (adds) a string of symbols in PDS.

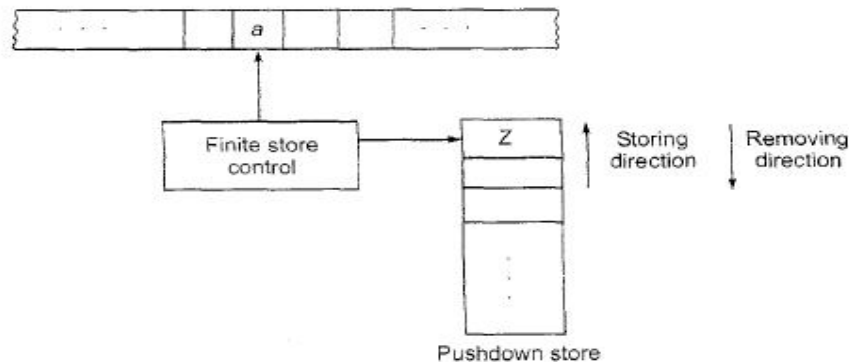
**Instantaneous description:**

Instantaneous description (ID) is the configuration of a PDA at a given instant. We define an ID to be a triple  $(q, w, \gamma)$ , where  $q$  is a state,  $w$  a string of input symbols, and  $\gamma$  a string of stack symbols.

**If  $M = (Q, \Sigma, \Gamma, \delta, q_0, Z_0, F)$  is a PDA, we say  $(q, aw, Z\alpha) \vdash_M (p, w, \beta\alpha)$  if  $\delta(q, a, Z)$  contains  $(p, \beta)$ . Note that  $a$  may be  $\epsilon$  or an input symbol.**

**Accepted Languages:**

For PDA  $M = (Q, \Sigma, \Gamma, \delta, q_0, Z_0, F)$  we define  $L(M)$ , the *language accepted by final state*, to be

$$\{w \mid (q_0, w, Z_0) \vdash^* (p, \epsilon, \gamma) \text{ for some } p \text{ in } F \text{ and } \gamma \text{ in } \Gamma^*\}.$$

We define  $N(M)$ , the *language accepted by empty stack (or null stack)* to be

$$\{w \mid (q_0, w, Z_0) \vdash^* (p, \epsilon, \epsilon) \text{ for some } p \text{ in } Q\}.$$

When acceptance is by empty stack, the set of final states is irrelevant, and, in this case, we usually let the set of final states be the empty set.

**Example:**

Design a PDA that accepts  $\{ww^R \mid w \text{ in } (0+1)^*\}$

$$L = \{ \epsilon, 0, 1, 00, 11, 0110, 1001, \dots \}$$

Let  $M = (Q, \Sigma, \Gamma, \delta, q_0, Z_0, F)$  be the PDA

Consider  $M = (\{q_1, q_2\}, \{0, 1\}, \{0, 1, Z_0\}, \delta, q_1, Z_0, \emptyset)$

$$\delta(q_1, 0, Z_0) = \{(q_1, 0Z_0)\}$$

$$\delta(q_1, 1, Z_0) = \{(q_1, 1Z_0)\}$$

$$\delta(q_1, 0, 0) = \{(q_1, 00), (q_2, \epsilon)\}$$

$$\delta(q_1, 1, 0) = \{(q_1, 10)\}$$

$$\delta(q_1, 0, 1) = \{(q_1, 01)\}$$

$$\delta(q_1, 1, 1) = \{(q_1, 11), (q_2, \epsilon)\}$$

$$\delta(q_2, 0, 0) = \{(q_2, \epsilon)\}$$

$$\delta(q_2, 1, 1) = \{(q_2, \epsilon)\}$$

$$\delta(q_1, \epsilon, Z_0) = \{(q_2, \epsilon)\}$$

$$\delta(q_2, \epsilon, Z_0) = \{(q_2, \epsilon)\}$$

**5.7.1 Deterministic PDA:**

The PDA is deterministic in the sense that at most one move is possible from any ID.

Formally we say a PDA  $M$  is deterministic if:

- 1) for each  $q$  in  $Q$  and  $Z$  in  $\Gamma$ , whenever  $\delta(q, \epsilon, Z)$  is nonempty, then  $\delta(q, a, Z)$  is empty for all  $a$  in  $\Sigma$ ;
- 2) for no  $q$  in  $Q$ ,  $Z$  in  $\Gamma$ , and  $a$  in  $\Sigma \cup \{\epsilon\}$  does  $\delta(q, a, Z)$  contain more than one element.



**Equivalence of PDA's and CFL's :****5.8 CFG to PDA Conversion**

If  $L$  is a context-free language, then there exists a PDA  $M$  such that  $L = N(M)$ .

*Procedure:*

Let  $L=L(G)$ , where  $G=(V_N, \Sigma, P, S)$  is a context free grammar.

We construct a PDA  $M$  as

$$M = (Q, \Sigma, V_N \cup \Sigma, Z_0, q, \delta, \emptyset)$$

Where  $\delta$  is defined by the following rules:

$$R1: \delta(q, \varepsilon, A) = \{(q, \alpha) \mid A \rightarrow \alpha \text{ is in } P\}$$

$$R2: \delta(q, a, a) = \{(q, \varepsilon)\} \text{ for every } a \text{ in } \Sigma.$$

***Example:***

Construct a pda  $M$  equivalent to the following context free grammar:

$$S \rightarrow 0BB$$

$$B \rightarrow 0S \mid 1S \mid 0.$$

Test whether  $010^4$  is in  $N(M)$ .

**Solution:**

Define pda  $A$  as follows:

$$A = (\{q\}, \{0, 1\}, \{S, B, 0, 1\}, \delta, q, Z_0, \emptyset)$$

$\delta$  is defined by the following rules:

$$R_1: \delta(q, \varepsilon, S) = \{(q, 0BB)\}$$

$$R_2: \delta(q, \varepsilon, B) = \{(q, 0S), (q, 0S), (q, 0)\}$$



$R_3: \delta(q, 0,0)=\{(q, \epsilon)\}$

$R_4: \delta(q, 1,1)=\{(q, \epsilon)\}$

### *String Checking*

$(q,010^4,S)$

$\vdash (q, 010^4, 0BB)$

by Rule  $R_1$

$\vdash (q, 10^4, BB)$

by Rule  $R_3$

$\vdash (q, 10^4, 1SB)$

by Rule  $R_2$  since  $(q,1S) \in \alpha(q, \Lambda, B)$

$\vdash (q, 0^4, SB)$

by Rule  $R_4$

$\vdash (q, 0^4, 0BBB)$

by Rule  $R_1$

$\vdash (q, 0^3, BBB)$

by Rule  $R_3$

$\vdash^* (q, 0^3, 000)$

by Rule  $R_2$  since  $(q,0) \in \alpha(q, \Lambda, B)$

$\vdash^* (q, \epsilon, \epsilon)$

by Rule  $R_3$

**UNIT - V**  
**Assignment-Cum-Tutorial Questions**  
**SECTION-A**

**Objective Questions**

1. Grammar that produce more than one Parse tree for same word is:
  - a) Ambiguous
  - b) Unambiguous
  - c) Complementation
  - d) Concatenation Intersection
2. For every grammar there will an equivalent grammar in CNF. [True/False]
3. The derivation trees of strings generated by a context free grammar in Chomsky Normal Form are always binary trees [True | False]
4. Which of the following conversion is not possible (algorithmically)?
  - a) Regular grammar to Context-free grammar
  - b) Nondeterministic FSA to Deterministic FSA
  - c) Nondeterministic PDA to Deterministic PDA
  - d) All of the above
5. CFL's are not closed intersection and complementation. [True | False]
6. CFL's are closed under
  - a) union
  - b) concatenation
  - c) closure
  - d) All
7. The grammar G with the productions  $A \rightarrow AA \mid (a) \mid \epsilon$  is an
  - a) Ambiguous grammar
  - b) Unambiguous grammar
  - c) Grammar
  - d) None
8. Identify the useless symbol in the grammar given below. [ ]
 
$$S \rightarrow AB \mid C \quad A \rightarrow a \quad B \rightarrow BC \quad C \rightarrow b$$
  - a) S
  - b) A
  - c) B
  - d) C
9. Find an equivalent reduced grammar for the given grammar. [ ]
 
$$S \rightarrow 0 \mid 1 \mid \epsilon \quad S \rightarrow 0S0 \mid 1S1$$
  - a)  $S \rightarrow 0 \mid 1, S \rightarrow 0S0 \mid 1S1 \mid 0 \mid 1$
  - b)  $S \rightarrow 0 \mid 1, S \rightarrow SS \mid 0S1 \mid 1S1$
  - c)  $S \rightarrow 0 \mid 1, S \rightarrow 00 \mid 11$
  - d) None
10. Which one of the following is a Chomsky Normal Form grammar?
  - (i)  $A \rightarrow BC \mid a$
  - (ii)  $A \rightarrow aA \mid a \mid b$
  - (iii)  $A \rightarrow BCD \mid a, B \rightarrow a, C \rightarrow c, D \rightarrow d$

- a) (i) only    b) (i) and (iii)    c) (ii) and (iii)    d) (i),(ii) and (iii)

11. Which one of the following is not a Greibach Normal form grammar?

- (i)  $S \rightarrow a \mid bA \mid aA \mid bB$     (ii)  $S \rightarrow a \mid aA \mid AB$     (iii)  $S \rightarrow a \mid A \mid aA$   
 $A \rightarrow a$      $A \rightarrow a$      $A \rightarrow a$   
 $B \rightarrow b$      $B \rightarrow b$      $B \rightarrow b$

- a) (i) and (ii)    b) (i) and (iii)    c) (ii) and (iii)    d) (i),(ii) and (iii)

12.  $L = \{ 0^n 1^{2n} \mid n \geq 1 \}$  is [    ]

- a) regular    b) context-free but not regular  
 c) context-free but regular    d) None

13. Recognize the language accepted by the PDA with the following moves [    ]

- $\delta ( q_0, a, Z_0 ) = ( q_0, aZ_0 )$ ,     $\delta ( q_0, a, a ) = ( q_0, aa )$   
 $\delta ( q_0, b, a ) = ( q_1, \epsilon )$ ,     $\delta ( q_1, b, a ) = ( q_1, \epsilon )$   
 $\delta ( q_1, c, Z_0 ) = ( q_2, Z_0 )$ ,     $\delta ( q_2, c, Z_0 ) = ( q_2, Z_0 )$

- a)  $L = \{ a^n b^n c^n \mid n, m \geq 1 \}$     b)  $L = \{ a^n b^n c^m \mid n, m \geq 1 \}$   
 c)  $L = \{ a^m b^n c^n \mid n, m \geq 1 \}$     d)  $L = \{ a^m b^n c^m \mid n, m \geq 1 \}$

14. What is the language generated by the grammar  $G = (V, T, P, S)$  where  
 $P = \{ S \rightarrow aSb, S \rightarrow ab \}$ ?

15. The grammars  $G_1$  and  $G_2$  are

$G_1: S \rightarrow 0S0 \mid 1S1 \mid 0 \mid 1 \mid \epsilon$

$G_2: S \rightarrow as \mid asb \mid X, X \rightarrow Xa \mid a.$

Which is the correct statement? [    ]

- a)  $G_1$  is ambiguous,  $G_2$  is unambiguous  
 b)  $G_1$  is unambiguous,  $G_2$  is ambiguous  
 c) Both  $G_1$  and  $G_2$  are ambiguous  
 d) Both  $G_1$  and  $G_2$  are unambiguous

## SECTION-B

### Descriptive questions

1. What is an ambiguous grammar? Explain with an example.
2. Define Useless symbol and give example.

3. Define Null and Unit productions. Give examples for each.
4. List all the applications of CFG.
5. List all the closure properties of CFL.
6. Explain pumping lemma for CFL's with an example.
7. Sketch and explain in detail the model of PDA.
8. Show that the grammar is ambiguous.
 
$$S \rightarrow 0A \mid 1B$$

$$A \rightarrow 0AA \mid 1S \mid 1$$

$$B \rightarrow 1BB \mid 0S \mid 0$$
9. Convert the following grammar in to GNF
 
$$S \rightarrow XA \mid BB$$

$$B \rightarrow b \mid SB$$

$$X \rightarrow b$$
10. Design PDA for  $L = \{wcw^r \mid w \in (0+1)^*\}$ .
11. Design PDA for the language  $L = \{a^n b^{n+m} c^m \mid n, m \geq 1\}$
12. What is the language generated by the grammar  $G=(V,T,P,S)$  where  $P=\{S \rightarrow aSb, S \rightarrow ab\}$ ?
13. For the following grammar :
 
$$S \rightarrow ABC \mid BbB, A \rightarrow aA \mid BaC \mid aaa, B \rightarrow bBb \mid a \mid D, C \rightarrow CA \mid AC, D \rightarrow \epsilon$$
  - i. Eliminate  $\epsilon$ -productions.
  - ii. Eliminate any unit productions in the resulting grammar.
  - iii. Eliminate any useless symbols in the resulting grammar.
  - iv. Put the resulting grammar in Chomsky Normal Form
14. Find a CFG, without  $\epsilon$  productions, unit productions and useless productions equivalent to the grammar defined by
 
$$S \rightarrow ABaC$$

$$A \rightarrow BC$$

$$B \rightarrow b \mid \epsilon$$

$$C \rightarrow D \mid \epsilon$$

$$D \rightarrow d$$
15. Obtain the PDA for the given regular language:
  - a.  $L = \{ww^r \mid w \text{ is in } (0+1)^*\}$ .
  - b. The language for even length palindrome, also show the moves of the PDA to accept the string 101101 for the above grammar.
16. Convert the following Context Free Grammar to Push Down Automata.
 
$$S \rightarrow aAA$$

$$A \rightarrow aS \mid bS \mid a$$
17. Convert the following Context Free Grammar to Push Down Automata
 
$$S \rightarrow (S)S \mid \epsilon$$

18. Convert the following Grammar into CNF.

$$S \rightarrow AbcD / abc$$

$$A \rightarrow aASB / d$$

$$B \rightarrow b / cb$$

$$D \rightarrow d$$

19. Consider the grammar  $(\{S, A, B\}, \{a, b\}, P, S)$  that has the productions:

$$S \rightarrow bA \mid aB$$

$$A \rightarrow bAA \mid aS \mid a$$

$$B \rightarrow aBB \mid bS \mid b$$

Find an equivalent grammar in CNF.

20. Prove that  $L = \{WW \mid w \text{ is bit string}\}$  is not Context Free Language.

21. Show that  $L = \{a^n b^n c^n \mid n \geq 0\}$  is not a context free language.

22. Show that  $L = \{a^i b^j \mid j = i^2\}$  is not context free language.

23. Eliminate the useless symbols from the following grammar.

$$S \rightarrow aS \mid A \mid C$$

$$A \rightarrow a$$

$$B \rightarrow aa$$

$$C \rightarrow aCb$$

24. Define ambiguity and Check whether the given grammar is ambiguous or not.

$$S \rightarrow iCtS$$

$$S \rightarrow iCtSeS$$

$$S \rightarrow a$$

$$C \rightarrow b$$

## SECTION-C

### Gate Questions

1. Which one of the following languages over  $\Sigma = \{a, b\}$  is NOT context-free?

[ ] [Gate 2019]

(a)  $\{a^n b^i \mid i \in \{n, 3n, 5n\}, n \geq 0\}$

(b)  $\{wa^n w^R b^n \mid w \in \{a, b\}^*, n \geq 0\}$

(c)  $\{ww^R \mid w \in \{a, b\}^*\}$

(d)  $\{wa^n b^n w^R \mid w \in \{a, b\}^*, n \geq 0\}$

2. Identify the language generated by the following grammar, Where S is the start variable.

[ ] [Gate 2017]

$$S \rightarrow XY$$

$$X \rightarrow aX \mid a$$

$$Y \rightarrow aYb \mid \text{epsilon}$$

A)  $\{a^m b^n \mid m \geq n, n > 0\}$

B)  $\{a^m b^n \mid m \geq n, n \geq 0\}$

C)  $\{a^m b^n \mid m > n, n \geq 0\}$

D)  $\{a^m b^n \mid m > n, n > 0\}$

3. Consider the following statements about the context free grammar



## UNIT VI

### Objective:

To understand and design Turing Machines for the given recursively enumerable languages.

### Syllabus:

**Turing Machine:** Turing Machine, model, Design of TM, Types of Turing Machines, Computable functions, Recursively enumerable languages.

**Computability Theory:** Decidability of problems, Undecidability of posts correspondence problem.

### Learning Outcomes:

Students will be able to:

- understand turing machine and its model.
- design Turing Machine's for Recursively Enumerable languages.
- define decidability and undecidability of problems.

## Learning Material

### 6.1 Turing Machine:

A Turing machine (TM) is denoted by

$$M = (Q, \Sigma, \Gamma, \delta, q_0, B, F),$$

where

- $Q$  is the finite set of *states*,
- $\Gamma$  is the finite set of allowable *tape symbols*,
- $B$ , a symbol of  $\Gamma$ , is the *blank*,
- $\Sigma$ , a subset of  $\Gamma$  not including  $B$ , is the set of *input symbols*,
- $\delta$  is the *next move function*, a mapping from  $Q \times \Gamma$  to  $Q \times \Gamma \times \{L, R\}$  ( $\delta$  may, however, be undefined for some arguments),
- $q_0$  in  $Q$  is the *start state*,
- $F \subseteq Q$  is the set of *final states*.

## **6.2 The Turing Machine Model:**

- The basic model has a finite control, an input tape that is divided into cells, and a tape head that scans one cell of the tape at a time.
- The tape has a leftmost cell but is infinite to the right. Each cell of the tape may hold exactly one of a finite number of tape symbols.
- Initially, the  $n$  leftmost cells, for some finite  $n \geq 0$ , hold the input, which is a string of symbols chosen from a subset of the tape symbols called the input symbols.
- The remaining infinity of cells each hold the blank, which is a special tape symbol that is not an input symbol.

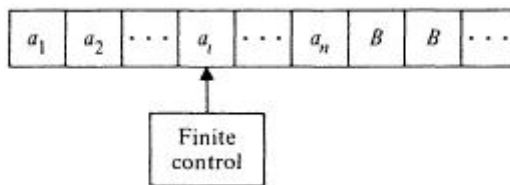

### **Moves of Turing Machine**

In one move the Turing machine, depending upon the symbol scanned by the tape head and the state of the finite control,

- 1) changes state,
- 2) prints a symbol on the tape cell scanned, replacing what was written there, and
- 3) moves its head left or right one cell.

Note : The difference between a Turing machine and a two-way finite automaton lies in the former's ability to change symbols on its tape.

### **Instantaneous description (ID):**

- Instantaneous description of the Turing machine  $M$  is denoted by  $\alpha_1 q \alpha_2$ .
- Here  $q$ , the current state of  $M$ , is in  $Q$ ;  $\alpha_1 \alpha_2$  is the string in  $\Gamma^*$  that is the contents of the tape up to the rightmost nonblank symbol or the symbol to the



left of the head, whichever is rightmost. (Observe that the blank B may occur in  $\alpha_1\alpha_2$ ).

- The tape head is assumed to be scanning the leftmost symbol of  $\alpha_2$ , or if  $\alpha_2 = \epsilon$ , the head is scanning a blank.

### Acceptance by Turning Machine

The language accepted by M, denoted  $L(M)$ , is the set of those words in  $\Sigma^*$  that cause M to enter a final state when placed, justified at the left, on the tape of M, with M in state  $q_0$ , and the tape head of M at the leftmost cell.

Formally, the language accepted by  $M = (Q, \Sigma, \Gamma, \delta, q_0, B, F)$  is

$$\{w \mid w \text{ in } \Sigma^* \text{ and } q_0 w \xrightarrow{*} \alpha_1 p \alpha_2 \text{ for some } p \text{ in } F, \text{ and } \alpha_1 \text{ and } \alpha_2 \text{ in } \Gamma^*\}.$$

### **Example:**

Design a TM to accept the language  $L = \{0^n 1^n \mid n \geq 1\}$ .

Initially, the tape of M contains  $0^n 1^n$  followed by infinity of blanks.

Repeatedly, M replaces the leftmost 0 by X, moves right to the leftmost 1, replacing it by Y, moves left to find the rightmost X, then moves one cell right to the leftmost 0 and repeats the cycle.

If, however, when searching for a 1, M finds a blank instead, then M halts without accepting.

If, after changing a 1 to a Y, M finds no more 0's, then M checks that no more 1's remain, accepting if there are none.

| State | 0             | 1             | Symbol<br>X   | Y             | B             |
|-------|---------------|---------------|---------------|---------------|---------------|
| $q_0$ | $(q_1, X, R)$ | —             | —             | $(q_3, Y, R)$ | —             |
| $q_1$ | $(q_1, 0, R)$ | $(q_2, Y, L)$ | —             | $(q_1, Y, R)$ | —             |
| $q_2$ | $(q_2, 0, L)$ | —             | $(q_0, X, R)$ | $(q_2, Y, L)$ | —             |
| $q_3$ | —             | —             | —             | $(q_3, Y, R)$ | $(q_4, B, R)$ |
| $q_4$ | —             | —             | —             | —             | —             |

### **The function $\delta$**

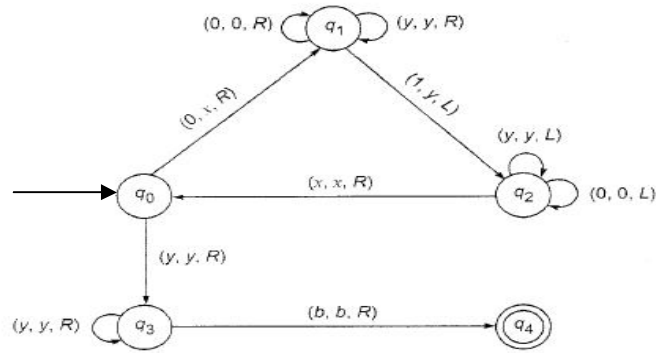

**Transition Diagram**

String Verification by Turning Machine

|           |            |           |           |
|-----------|------------|-----------|-----------|
| $q_00011$ | $Xq_1011$  | $X0q_111$ | $Xq_20Y1$ |
| $q_2X0Y1$ | $Xq_00Y1$  | $XXq_1Y1$ | $XXYq_11$ |
| $XXq_2YY$ | $Xq_2XYY$  | $XXq_0YY$ | $XXYq_3Y$ |
| $XXYYq_3$ | $XXYYBq_4$ |           |           |

**A computation of M**

**6.3 Types of Turing Machines:**

**i) Two-way infinite tape:**

A Turing machine with a two-way infinite tape is denoted by  $M = (Q, \Sigma, \Gamma, \delta, q_0, B, F)$ . As its name implies, the tape is infinite to the left as well as to the right. We denote an ID of such a device as for the one-way infinite TM. We imagine, however, that there is an infinity of blank cells both to the left and right of the current nonblank portion of the tape.

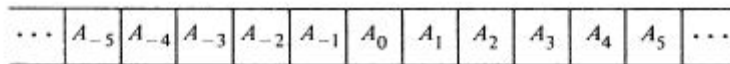

**ii) Multitape Turing machines:**

A multitape Turing machine consists of a finite control with k tape heads and k tapes; each tape is infinite in both directions.. On a single move, depending on the

state of the finite control and the symbol scanned by each of the tape heads, the machine can:

- 1) change state;
- 2) print a new symbol on each of the cells scanned by its tape heads;
- 3) move each of its tape heads,, independently, one cell to the left or right, or keep it stationary.

Initially, the input appears on the first tape, and the other tapes are blank.

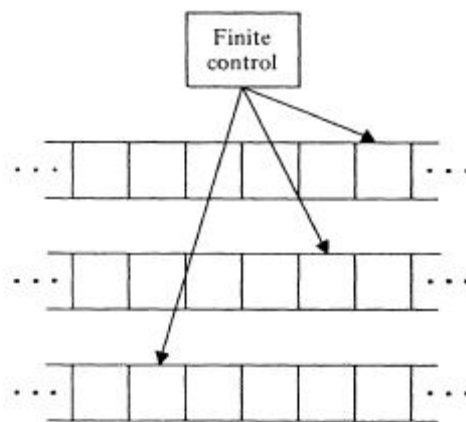

### **iii) Nondeterministic Turing machines:**

A nondeterministic Turing machine is a device with a finite control and a single, one-way infinite tape. For a given state and tape symbol scanned by the tape head, the machine has a finite number of choices for the next move. Each choice consists of a new state, a tape symbol to print, and a direction of head motion. Note that the nondeterministic TM is not permitted to make a move in which the next state is selected from one choice, and the symbol printed and/or direction of head motion are selected from other choices. The nondeterministic TM accepts its input if any sequence of choices of moves leads to an accepting state.

### **iv) Multidimensional Turing machines:**

The device has the usual finite control, but the tape consists of a  $k$ -dimensional array of cells infinite in all  $2k$  directions, for some fixed  $k$ . Depending on the state

and symbol scanned, the device changes state, prints a new symbol, and moves its tape head in one of  $2k$  directions, either positively or negatively, along one of the  $k$  axes. Initially, the input is along one axis, and the head is at the left end of the input. At any time, only a finite number of rows in any dimension contain nonblank symbols, and these rows each have only a finite number of nonblank symbols.

|       |          |          |          |       |          |          |
|-------|----------|----------|----------|-------|----------|----------|
| $B$   | $B$      | $B$      | $a_1$    | $B$   | $B$      | $B$      |
| $B$   | $B$      | $a_2$    | $a_3$    | $a_4$ | $a_5$    | $B$      |
| $a_6$ | $a_7$    | $a_8$    | $a_9$    | $B$   | $a_{10}$ | $B$      |
| $B$   | $a_{11}$ | $a_{12}$ | $a_{13}$ | $B$   | $a_{14}$ | $a_{15}$ |
| $B$   | $B$      | $a_{16}$ | $a_{17}$ | $B$   | $B$      | $B$      |

**v) Multihead Turing machines:**

A  $k$ -head Turing machine has some fixed number,  $k$ , of heads. The heads are numbered 1 through  $k$ , and a move of the TM depends on the state and on the symbol scanned by each head. In one move, the heads may each move independently left, right, or remain stationary.

**vi) Off-line Turing machines:**

An off-line Turing machine is a multitape TM whose input tape is read-only. Usually we surround the input by endmarkers,  $\$$  on the left and  $\$$  on the right. The Turing machine is not allowed to move the input tape head off the region between  $\$$  and  $\$$ .

**6.4 Recursive function:** a function which calls itself directly or indirectly and terminates after finite number of steps.

**Total recursive function**

- A function is called total recursive function if it is defined for all its arguments.

- Let  $f(a_1, a_2, \dots, a_n)$  be a function and defined on function  $g(b_1, b_2, \dots, b_m)$ , then  $f$  is total function if every element of  $f$  is assigned to some unique element of function  $g$ .
- From the definition it is clear that total recursive function is the subset of partial recursive function.
- All those partial functions for which TM halts are called total recursive functions.

### **Partial recursive function**

- A function is called partial recursive function if it is defined for some of its arguments.
- Let  $f(a_1, a_2, \dots, a_n)$  be a function and defined on function  $g(b_1, b_2, \dots, b_m)$ , then  $f$  is partial function if some elements of  $f$  is assigned to almost one element of function  $g$ .
- Partial recursive function are turing computable. It means that there exist a turing machine for every partial recursive function.

### **6.5 Recursively enumerable languages**

A language that is accepted by a Turing machine is said to be recursively enumerable (r.e.).

- Recursively enumerable languages are equivalent to the class of partial recursive functions.

### **Recursive Language:**

A subclass of the r.e. sets, called the recursive sets, which are those languages accepted by at least one Turing machine that halts on all inputs.

**Decidable and undecidable problems:**

- A problem whose language is recursive is said to be decidable.
- A problem is undecidable if there is no algorithm that takes as input an instance of the problem and determines whether the answer to that instance is "yes" or "no."

**6.6 Post's Correspondence Problem:**

An instance of Post's Correspondence Problem (PCP) consists of two lists,  $A = w_1, \dots, w_k$  and  $B = x_1, \dots, x_k$ , of strings over some alphabet  $\Sigma$ . This instance of PCP has a solution if there is any sequence of integers  $i_1, i_2, \dots, i_m$ , with  $m \geq 1$ , such that  $w_{i_1} w_{i_2} \dots w_{i_m} = x_{i_1} x_{i_2} \dots x_{i_m}$ .

The sequence  $i_1, \dots, i_m$  is a solution to this instance of PCP.

***Example 1:***

Let  $\Sigma = \{0, 1\}$ . Let A and B be lists of three strings each, as defined

|     | List A | List B |
|-----|--------|--------|
| $i$ | $w_i$  | $x_i$  |
| 1   | 1      | 111    |
| 2   | 10111  | 10     |
| 3   | 10     | 0      |

In this case PCP has a solution. Let  $m = 4$ ,  $i_1 = 2, i_2 = 1, i_3 = 1$ , and  $i_4 = 3$ . Then  $w_2 w_1 w_1 w_3 = x_2 x_1 x_1 x_3 = 101111110$ .

***Example 2:*** Show that PCP problem with 2 lists

$X = (b, bab^3, ba)$  and  $y = (b^3, ba, a)$  has a solution.

Given lists are  $x=(b,bab^3,ba)$   $y=(b^3,ba,a)$

The instances of PCP is as follows

|   | List X  | List Y |
|---|---------|--------|
| i | $X_i$   | $Y_i$  |
| 1 | a       | $b^3$  |
| 2 | $bab^3$ | ba     |
| 3 | ba      | a      |

In this case PCP is as follows

$$X_2X_1X_3=Y_2Y_1Y_3=bab^3bbba$$

The solution sequence is 2113 PCP has a solution.

**Example 3:** Prove that PCP with two lists  $X=(01,1,1)$   $Y=(0101,10,11)$  has no solution.

sol) Instance of PCP is given as

|   | List X | List Y |
|---|--------|--------|
| i | $X_i$  | $Y_i$  |
| 1 | 01     | 0101   |
| 2 | 1      | 10     |
| 3 | 1      | 11     |

Where  $X_1=01$   $Y_1=0101$

$$X_2=1 \quad Y_2=10$$

$$X_3=1 \quad Y_3=11$$

For any  $i$   $|X_i| < |Y_i|$  The last  $Y$  is having strings of greater lengths. So to get same string for same sequences of  $x_1, x_2, x_3$  and  $y_1, y_2, y_3$  is difficult.

We cannot get solution sequence. Therefore the given PCP is having no solution.



## UNIT - VI

### Assignment-Cum-Tutorial Questions

#### SECTION-A

#### Objective Questions

1. The language accepted by a Turing machine is called \_\_\_\_\_ language.
2. The move function of Turing Machine is \_\_\_\_\_.
3. Recursively enumerable languages are equivalent to the class of \_\_\_\_\_ functions.
4. Recursively enumerable languages are closed under complementation.  
[True | False]
5. The set of all recursive languages is a subset of the set of all recursively enumerable languages.  
[True | False]
6. Total recursive function is a special case of partial recursive function.  
[True | False]
7. The power of Non-deterministic Turing machine and deterministic Turing Machine are same.  
[True | False]
8. A problem whose language is recursive is called \_\_\_\_\_.
9. Recursive languages are [     ]
  - a. A proper subset of CFL
  - b. Also called Type 0 languages
  - c) Always recognizable by PDA
  - d) Recognizable by TM
10. If L is recursively enumerable language then complement of L is also recursively enumerable.  
[True | False]
11. Which of the following languages are accepted by a Turing Machine?
  - (i)  $L = \{a^n b^n \mid n \geq 0\}$  [     ]
  - (ii)  $L = \{a^n b^{2n} c^{2n} \mid n \geq 0\}$
  - (iii) The set of palindromes over alphabet  $\{a, b\}$
 a). Only (i)   b). Only (ii)   c). (i) and (iii)   d). (i), (ii) and (iii)
12. A single tape Turing Machine M has three states  $q_0, q_1$  and  $q_2$ , of which  $q_0$  is the starting state. The tape alphabet of M is  $\{0, 1, B\}$  and its input alphabet is  $\{0, 1\}$ . The symbol B is the blank symbol used to indicate end of an input string. The transition function of M is described in the following table

|    |        |        |        |
|----|--------|--------|--------|
|    | 0      | 1      | B      |
| q0 | q0,1,R | q0,0,R | q1,B,L |
| q1 | q1,0,L | q1,1,L | q2,B,R |

Which of the following statements is true about M?

- a) M halts after computing 1's complement of a binary number
- b) M halts after computing 2's complement of a binary number
- c) M halts after reversing of a binary number
- d) None

13. The given table represents a turing machine which accepts [       ]

|                  |                   |
|------------------|-------------------|
| Present state    | 1                 |
| → q <sub>1</sub> | bq <sub>2</sub> R |
| q <sub>2</sub>   | bq <sub>1</sub> R |

- a) even number of 1's
- b) odd number of 1's
- c) even number of 1's and odd number of 1's
- d) even number of 1's or odd number of 1's

14. The transitions of a turing Machine are given below

$$\delta (q_0, 1) = (q_0, 1, R)$$

$$\delta (q_0, B) = (q_1, 1, R)$$

$$\delta (q_1, B) = (q_2, B, R)$$

The input on the tape is q011B then the output on the tape is [       ]

- a) 111Bq<sub>2</sub>B
- b) 1111Bq<sub>2</sub>B
- c) 111Bq<sub>1</sub>B
- d) 1111Bq<sub>1</sub>B

**SECTION-B**

**Descriptive questions**

1. Define Turning Machine. Explain about model of Turning Machine
2. Explain various types of Turing machines.
3. Write short notes on halting problem of a Turing Machine.
4. What is post correspondence problem? Explain with an example
5. Design TM for the language  $L = \{a^n b^n c^n \mid n \geq 1\}$
6. Design TM for the language  $L = \{a^n b^m c^{n+m} \mid n, m \geq 1\}$
7. Design a Turing machine that accepts the language  $L = \{ W W^R \mid W \in (0+1)^* \text{ and } W^R \text{ is reverse of } W\}$

8. Construct a Turing Machine for checking the palindrome of the string of even length over  $\Sigma = \{a,b\}$ .
9. Construct a Turing machine M for  $\Sigma = \{a, b\}$  which will convert lower case letters to upper case.
10. Construct a Turing machine M, which recognizes the language  $L = \{wcw \mid w \in (a + b)^+\}$ .
11. Design TM to perform addition of 2 intergers.
12. Consider the TM described by the transition table given below. Which of the strings are accepted by TM? Represent the processing of strings using ID's.  
 a) 011      b) 0011

| Present state     | Tape symbol |         |         |          |         |
|-------------------|-------------|---------|---------|----------|---------|
|                   | 0           | 1       | x       | y        | b       |
| $\rightarrow q_1$ | $xRq_2$     |         |         |          | $bRq_5$ |
| $q_2$             | $0Rq_2$     | $yLq_3$ |         | $yRq_2$  |         |
| $q_3$             | $0Lq_4$     |         | $xRq_5$ | $yLq_3$  |         |
| $q_4$             | $0Lq_4$     |         | $xRq_1$ |          |         |
| $q_5$             |             |         |         | $yxRq_5$ | $bRq_5$ |
| $q_6$             |             |         |         |          |         |

13. Design TM for subtraction of two numbers.
14. Show that the following post correspondence problem has a solution and give the solution.

| i | ListA | ListB |
|---|-------|-------|
| 1 | 11    | 11    |
| 2 | 100   | 001   |
| 3 | 111   | 11    |

**SECTION-C**

**Gate Questions**

1. The set of all recursively enumerable languages is **[GATE 2018]** [    ]  
 a) closed under complementation  
 b) closed under intersection  
 c) a subset of the set of all recursive languages  
 d) an uncountable set

2. Consider the following types of languages: **[GATE 2016]** [   ]  
 L1 Regular,      L2: Context-free,  
 L3: Recursive,    L4: Recursively enumerable.  
 Which of the following is/are TRUE?  
 I.  $L3' \cup L4$  is recursively enumerable      II.  $L2 \cup L3$  is recursive  
 III.  $L1^* \cup L2$  is context-free                  IV.  $L1 \cup L2'$  is context-free  
 a) I only      b) I and III only      c) I and IV only      d) I, II and III only
3. Which of the following statements is/are FALSE?**[GATE 2013]**[   ]  
 1. For every non-deterministic Turing machine, there exists an equivalent deterministic Turing machine.  
 2. Turing recognizable languages are closed under union and complementation.  
 3. Turing decidable languages are closed under intersection and complementation.  
 4. Turing recognizable languages are closed under union and intersection.  
 a) 1 and 4 only      b) 1 and 3 only      c) 2 only      d) 3 only
4. Let L1 be a recursive language. Let L2 and L3 be languages that are recursively enumerable but not recursive. Which of the following statements is not necessarily true? **[GATE 2010]**[   ]  
 (A)  $L2 - L1$  is recursively enumerable    (B)  $L1 - L3$  is recursively enumerable  
 (C)  $L2 \cap L1$  is recursively enumerable    (D)  $L2 \cup L1$  is recursively enumerable  
 a)A      b)B      c)C      d)D
5. Which of the following is true for the language  $\{a^p \mid p \text{ is a prime}\}$ ?  
**[GATE 2008]**[   ]  
 a) It is not accepted by a Turing Machine  
 b) It is regular but not context-free  
 c) It is context-free but not regular  
 d) It is neither regular nor context-free, but accepted by a Turing machine
6. If L and L' are recursively enumerable, then L is **[GATE 2008]**[   ]  
 a) regular      b) context-free      c) Context-sensitive      d) recursive
7. Let L1 be a recursive language, and let L2 be a recursively enumerable but not a recursive language. Which one of the following is TRUE?  
**[GATE 2005]**[   ]  
 L1' --> Complement of L1  
 L2' --> Complement of L2  
 a) L1' is recursive and L2' is recursively enumerable  
 b) L1' is recursive and L2' is not recursively enumerable  
 c) L1' and L2' are recursively enumerable

d)  $L_1'$  is recursively enumerable and  $L_2'$  is recursive

8. A single tape Turing Machine  $M$  has two states  $q_0$  and  $q_1$ , of which  $q_0$  is the starting state. The tape alphabet of  $M$  is  $\{0, 1, B\}$  and its input alphabet is  $\{0, 1\}$ . The symbol  $B$  is the blank symbol used to indicate end of an input string. The transition function of  $M$  is described in the following table

**[GATE 2003]** [      ]

|       |             |             |             |
|-------|-------------|-------------|-------------|
|       | 0           | 1           | B           |
| $q_0$ | $q_1, 1, R$ | $q_1, 1, R$ | Halt        |
| $q_1$ | $q_1, 1, R$ | $q_0, 1, L$ | $q_0, B, L$ |

The table is interpreted as illustrated below. The entry  $(q_1, 1, R)$  in row  $q_0$  and column 1 signifies that if  $M$  is in state  $q_0$  and reads 1 on the current tape square, then it writes 1 on the same tape square, moves its tape head one position to the right and transitions to state  $q_1$ . Which of the following statements is true about  $M$ ?

- a)  $M$  does not halt on any string in  $(0+1)^+$   
 b)  $M$  does not halt on any string in  $(00+1)^+$   
 c)  $M$  halts on all string ending in a 0  
 d)  $M$  halts on all string ending in a 1
9. Define languages  $L_0$  and  $L_1$  as follows : **[GATE 2003]** [      ]

$L_0 = \{ \langle M, w, 0 \rangle \mid M \text{ halts on } w \}$

$L_1 = \{ \langle M, w, 1 \rangle \mid M \text{ does not halts on } w \}$

Here  $\langle M, w, i \rangle$  is a triplet, whose first component,  $M$  is an encoding of a Turing Machine, second component,  $w$ , is a string, and third component,  $i$ , is a bit. Let  $L = L_0 \cup L_1$ . Which of the following is true?

- a)  $L$  is recursively enumerable, but  $L'$  is not  
 b)  $L'$  is recursively enumerable, but  $L$  is not  
 c) Both  $L$  and  $L'$  are recursive  
 d) Neither  $L$  nor  $L'$  is recursively enumerable
10. Nobody knows yet if  $P = NP$ . Consider the language  $L$  defined as follows :

$$L = \begin{cases} (0+1)^* & \text{if } P = NP \\ \phi & \text{otherwise} \end{cases}$$

**[GATE 2003]** [      ]

Which of the following statements is true?

- a)  $L$  is recursive  
 b)  $L$  is recursively enumerable but not recursive  
 c)  $L$  is not recursively enumerable  
 d) Whether  $L$  is recursive or not will be known after we find out if  $P = NP$
11. Which of the following is true? **[GATE 2002]** [      ]

- a) The complement of a recursive language is recursive.
- b) The complement of a recursively enumerable language is recursively enumerable.
- c) The complement of a recursive language is either recursive or recursively enumerable.
- d) The complement of a context-free language is context-free